

WD 1 (M) /

WD 1000

Operating Manual



WD 1 (M) WD 1000 Equipment overview

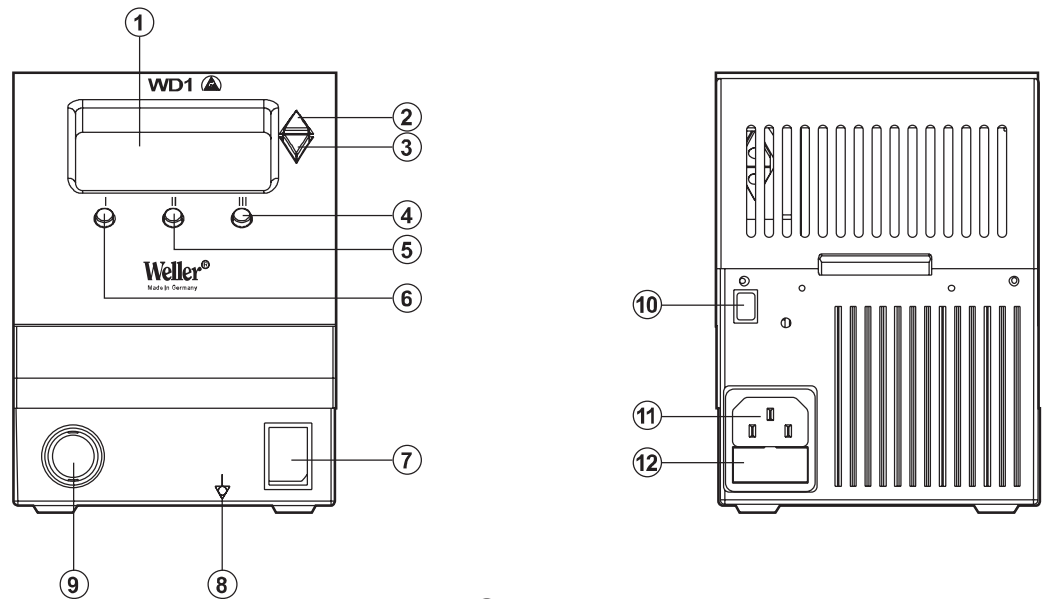

- 1 Display
- 2 UP button
- 3 DOWN button
- 4 Temperature button III
- 5 Temperature button II
- 6 Temperature button I
- 7 Mains switch
- 8 Equipotential-bonding socket
- 9 Connecting socket for soldering tool
- 10 USB interface, B-Mini (WD 1M optional)
- 11 Mains connection
- 12 Mains system fuse
- 13 Temperature display
- 14 Temperature symbol
- 15 Time function
- 16 Lock
- 17 Optical control check
- 18 Temperature buttons
- 19 Fixed temperature display
- 20 Special functions
- 21 Funnel insert
- 22 Soldering tip compartment
- 23 Cleaning element

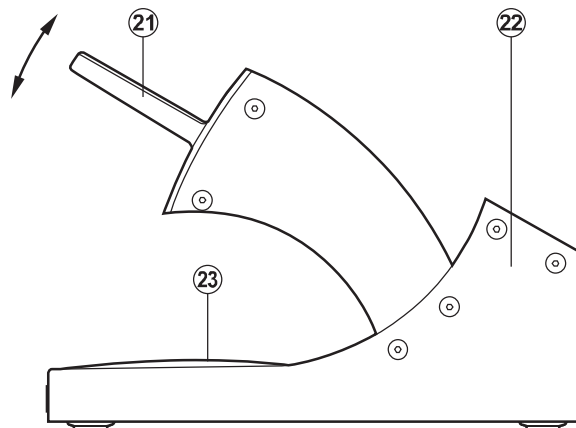
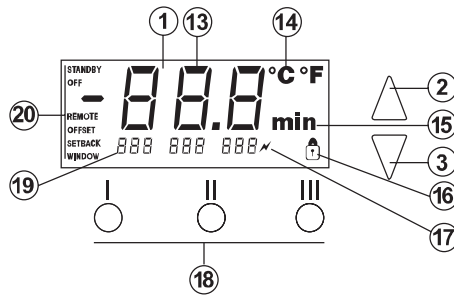

Contents

1	About these instructions	3
2	For your safety.....	4
3	Scope of supply	4
4	Device description	5
5	Starting up the device	7
6	Operating the device.....	8
7	Special functions.....	9
8	Resetting to factory settings	17
9	WD 1 (M) / WD 1000 care and maintenance.....	17
10	Fault messages and fault elimination	17
11	Accessories	18
12	Disposal.....	18
13	Warranty	18

1 About these instructions

Thank you for placing your trust in our company by purchasing the Weller WD 1 (M) / WD 1000. The device has been manufactured in accordance with the most rigorous quality standards, which ensure that the device operates perfectly.

These instructions contain important information for safe and correct initial operation of the WD 1 (M) / WD 1000 soldering station, including continued operation, maintenance and self-correction of simple faults.

- ▷ Read these instructions and the accompanying safety information carefully before switching on the device and starting work with the WD 1 (M) / WD 1000 soldering station.
- ▷ Make sure that all users have access to these instructions.

1.1 Applied directives

The Weller microprocessor-controlled WD 1 (M) / WD 1000 soldering station conforms to the specifications of the EC Declaration of Conformity with Directives 2004/108/EC and 2006/95/EC.

1.2 Documents also applicable

- Operating instructions for soldering station WD 1 (M) / WD 1000
- Safety information booklet accompanying these instructions

2 For your safety

The WD 1 (M) / WD 1000 soldering station has been manufactured in accordance with state-of-the-art technology and recognised technical safety regulations. There is nevertheless the risk of personal injury and damage to property if you fail to observe the safety information set out in the accompanying booklet and the warnings given in these instructions. Always pass on the WD 1 (M) / WD 1000 soldering station to third parties together with these operating instructions.

2.1 Specified use

Use the WD 1 (M) / WD 1000 soldering station exclusively for the purpose indicated in the operating instructions of soldering and unsoldering under the conditions specified here. Specified use of the WD 1 (M) / WD 1000 soldering station also includes

- observing these operating instructions,
- observing **all** other accompanying documentation,
- observing **locally** applicable accident prevention regulations.

The manufacturer shall not be liable for damage resulting from unauthorised alterations to the machine.

3 Scope of supply

	WD 1	WD 1000	WD 1M
Control unit	✓	✓	✓
Power cable	✓	✓	✓
Jack connector	✓	✓	✓
Soldering iron		✓	✓
Safety holder		✓	✓
Operating instructions	✓	✓	✓
Safety information booklet	✓	✓	✓

4 Device description

The Weller WD 1 (M) / WD 1000 is a versatile soldering station for performing professional repair work on state-of-the-art electronic assemblies in the industrial engineering sector as well as repair workshops and laboratories.

Precise temperature control performance at the soldering tip is guaranteed by the digital control electrotechnology together with superior-quality sensor and heat-transfer technology. High-speed measured-value acquisition provides for maximum temperature precision and optimum dynamic temperature performance in load situations.

All soldering irons (except for microtools) up to 80 Watts can be connected to the WD 1. The temperature range is from 50 °C to 450 °C (150 °F to 850 °F). The WD 1M is multifunctional and all soldering irons up to 150 Watts and microtools (WMRP & WMRT) can be connected; the temperature range is from 50 °C to 450 °C (150 °F to 850 °F). Setpoint and actual values are displayed in digital form. Three temperature buttons are used to select fixed temperatures directly. A flashing optical control check ("✓" symbol on display) indicates that the preselected tool temperature has been reached.

The Weller WD 1 (M) / WD 1000 soldering station also offers the following functions:

- Automatic tool detection and activation of corresponding control parameters
- Digital temperature control
- Option of inputting offset values
- Programmable temperature reduction (setback)
- Standby and lock functions
- Antistatic device design in accordance with ESD safety
- Different equipotential-bonding possibilities on the device (standard configuration hard earthed)
- Customer-specific calibration function

4.1 Safety holder

The funnel insert (21) for holding the soldering iron has four different settings and can be adjusted to the most ergonomic position without requiring tools. There is a compartment (22) on the back for storing soldering tips. The base plate on the compartment contains a cleaning element (23) for cleaning the soldering tip.

4.2 Technical data WD 1 (M) / WD 1000

Dimensions	L x W x H (mm): 134 x 108 x 147 L x W x H (inches): 5.27 x 4.27 x 5.77
Weight	approx. 3.4 kg
Mains supply voltage	230 V, 50/60 Hz 120 V, 60 Hz 100 V, 50/60 Hz
Power consumption	95 W
Safety class	I and III, housing antistatic
Fuse (12)	T 500 mA (230 V, 50 / 60 Hz)
Only WD 1 / WD 1000	T 1.0 A (120 V, 60 Hz) T 1.25 A (100 V, 50 / 60 Hz)
Fuse (12)	T 800 mA (230 V, 50 / 60 Hz)
Only WD 1 M/ WD 1000M	T 1.6 A (120 V, 60 Hz) T 1.6 A (100 V, 50 Hz)
Temperature control	50 °C – 450 °C (150 °F – 842 °F)
Temperature accuracy	± 9 °C (± 17 °F)
Temperature stability	± 5 °C (± 9 °F)
Soldering tip leakage resistance (tip to ground)	Complies with IPC-J-001D
Soldering tip leakage current (tip to ground)	Complies with IPC-J-001D
Equipotential bonding	Via 3.5 mm pawl socket on back of device (8).

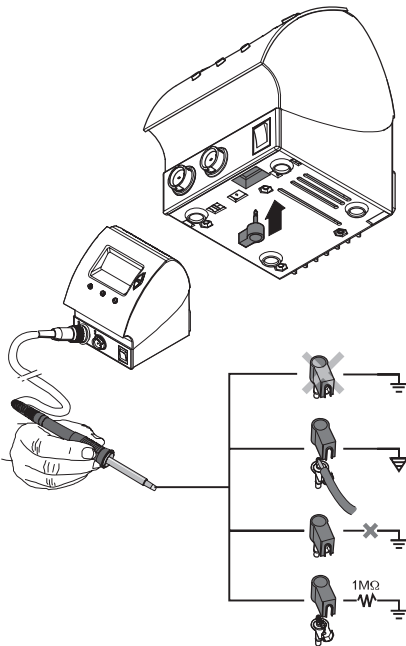

Equipotential bonding

4 variants are possible through connecting the 3.5 mm pawl socket (8) differently:

- Hard earthed/grounded: without connector (delivery status)
- Equipotential bonding: with connector, bonding line at central contact
- Floating: with connector
- Soft earthed/grounded: with connector and soldered resistor. Earthing/grounding via the selected resistor

USB port

The control units WD 1M is fitted with a mini USB interface (10). For the purpose of using the USB port, Weller software is available on a CD with which you

- can carry out a software update ("Firmware Updater") on your control unit and
- can remote-control the control unit and graphically display, store and print temperature curves ("Monitor Software").

Note Control units WD 1 and WD 1M can be retrofitted with a USB interface (accessories section on page 18).

5 Starting up the device

WARNING! Electric shock and risk of burns



Connecting the control unit incorrectly poses a risk of injury and damage to the device. Risk of burns from the soldering tool while the control unit is operating.

- ▷ Read the enclosed instructions, the safety instructions included in these Operating Instructions as well as the instructions for your control unit all the way through and observe the specified precautionary measures before operating the control unit.
- ▷ Always place the soldering tool in the safety holder when not in use.

1. Carefully unpack the device.
2. Connect the soldering tools as follows:
 - Insert the soldering tool with connector into the connecting socket (9) on the control unit and turn clockwise to lock.
3. Place the soldering tool in the safety holder.
4. Check whether the mains supply voltage matches that indicated on the rating plate and whether mains power switch (7) is off.
5. Connect the control unit to the mains supply (11).
6. Switch on the device at the mains power switch (7).

After the device has been switched on, the microprocessor carries out a self-test in which all the display elements are briefly in operation. The preset temperature (setpoint) and the temperature unit (°C / °F) are then displayed briefly. The electronics automatically switch to the actual value display. The symbol " ~ " (17) appears on the display (1) as an optical control check:

- Continuous illumination indicates that the system is warming up.
- Flashing light indicates that the preselected temperature has been reached.

Note Please refer to the accessories section on page 18 for a list of tools that can be connected to the WD 1 (M) / WD 1000.

6 Operating the device

6.1 Setting the temperature

Setting the temperature individually

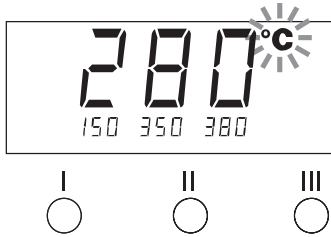

1. Switch on the device at the mains power switch (7).
The display indicates the actual temperature value.
2. Press the **UP** or **DOWN** button.
The display switches to the preset setpoint value. The temperature symbol (14) flashes.
3. Press the **UP** or **DOWN** button to set the desired setpoint temperature:
 - Brief touching alters the setpoint value by one degree.
 - Permanent pressing alters the setpoint value in rapid pass mode.

The actual value of the selected channel appears in the display again approx. 2 seconds after the setting buttons are released.

4. Press the **UP** and **DOWN** buttons simultaneously.
If the channel is now inactive, "OFF" appears in the display.
If the channel is now activated, the current actual temperature appears in the display.
Stored data is not lost when a channel is switched off.

Selecting the temperature with temperature buttons I, II and III

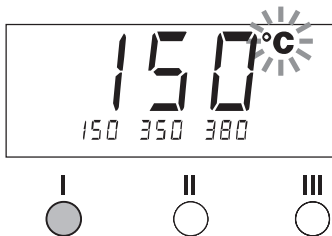

The setpoint temperature value can be set by selecting three preset temperature values (fixed temperatures).

Factory settings:

I = 150 °C (300 °F), **II** = 350 °C (662 °F), **III** = 380 °C (716 °F)

- ▷ Press the required temperature button **I**, **II** or **III**.

The selected setpoint appears on the display for approx. 2 s. The temperature symbol flashes while the setpoint is displayed.

The unit switches back to the actual value display automatically.

Setting the value of temperature buttons I, II and III

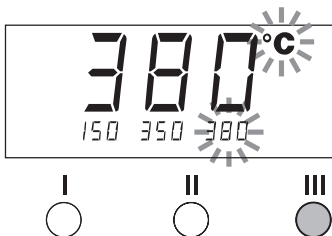

1. Press the required temperature button **I**, **II** or **III**.
2. Set the setpoint temperature value with the **UP** or **DOWN** button.
3. Press and hold the required temperature button **I**, **II** or **III** for three seconds.

The temperature display for the corresponding temperature value flashes during this period. The set value is stored after 3 seconds.

4. Release the temperature button again.

Note Assigning a low "Setback" temperature to a temperature button offers the possibility of manual temperature reduction when the soldering bit is not in use.

6.2 Soldering and unsoldering

- ▷ Carry out the soldering work in accordance with the operating instructions of your connected soldering tool.

Handling soldering tips

- Coat the tin-plated soldering tip with solder when heating the iron for the first time as this will remove any oxide films or impurities from the soldering tip that have accumulated during storage.
- During pauses between soldering and before storing the soldering iron, ensure that the soldering tip is well-coated.
- Do not use aggressive fluxing agents.
- Always make sure that the soldering tip is seated correctly.
- Select the lowest possible working temperature.
- Select the largest possible soldering tip shape for the application: approx. as large as the soldering pad
- Coat the soldering tip well to ensure efficient heat transfer between the soldering tip and soldering point.
- Switch off the system if you do not intend to use the soldering iron for longer periods or activate the Weller temperature reduction function
- Coat the tip before placing the soldering iron in the holder.
- Apply the solder directly at the soldering point, not on the soldering tip.
- Change the soldering tip using an appropriate tool.
- Do not subject the soldering tip to physical force.

Note The control units have been adapted to hold a medium-sized soldering tip. Discrepancies may occur if the tip is changed or a different shaped tip is used.

7 Special functions

▲ ▼	2 s ⇒	Menu 1
▲ ▼	4 s ⇒	Menu 2
▲ ▼	1x ⇒	ON/OFF

The special functions are divided into 2 menu levels:

- Menu 1 with options for setting the standby temperature, temperature cut-off (setback), automatic shut-off time (Auto OFF), temperature offset, window function, temperature units and locking function.
- Menu 2 with options for setting the ID code and calibration function (FCC).

7.1 Selecting Menu 1 special functions

Special functions	Navigation
STANDBY	↑ I
SETBACK	
AUTO OFF	
OFFSET	↓ II
WINDOW	
°C / °F	EXIT III
	

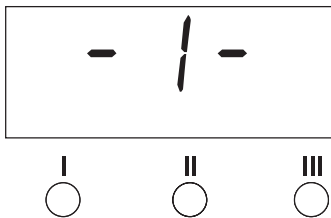

1. Press and hold down the **UP** and **DOWN** buttons simultaneously. "– 1 –" appears in the display after 2 s.
2. Release the buttons. Selection of the special functions of Menu 1 is activated. The settings can now be made.
 - Press the **I**, **II** buttons to select menu items.
 - Press the **III** button to exit the menu again (EXIT).

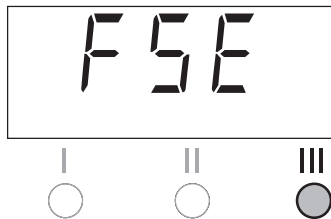

Resetting the special functions to the factory settings

1. Press and hold down button **III**.
2. Then press the **UP** and **DOWN** buttons simultaneously. "FSE" appears in the display. The soldering station is now reset to the factory settings.

Setting the standby temperature

The standby temperature is automatically set after a temperature deactivation. The actual temperature flashes in the display. "STANDBY" appears on the display (100 °C – 300 °C / 200 °F – 600 °F).

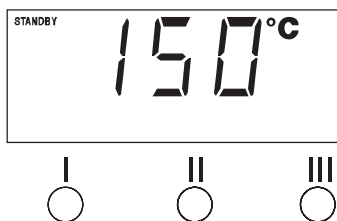

1. Select the menu item STANDBY in Menu 1.
2. Set the setpoint value for the standby temperature with the **UP** or **DOWN** button.
3. Press the **I** (back) or **II** (forwards) button to switch to the next menu item.

Setting temperature deactivation (SETBACK)

When the soldering tool is not in use, the temperature is reduced to the standby temperature after the set setback time has elapsed. The setback state is indicated by a flashing actual value and "STANDBY" appears in the display. Pressing the **UP** or **DOWN** button terminates this setback state. Depending on the tool, the finger switch or the switching holder deactivates the setback state.

The following setback settings are possible:

- "0 min": setback OFF (factory setting)
- "ON": setback ON (the system is controlled down to standby temperature with the switching holder after the soldering bit is stowed)
- "1-99 min": setback ON (individually settable setback time)
 1. Select the menu item SETBACK in Menu 1.
 2. Set the setback value with the **UP** or **DOWN** button.
 3. Press the **I** (back) or **II** (forwards) button to switch to the next menu item.

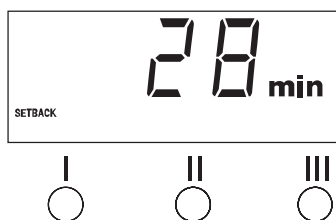

Note In the case of soldering work with low heat requirements, the reliability of the Setback function may be impaired.

Setting the automatic switch-off time (AUTO-OFF)

When the soldering tool is not in use, heating of the soldering tool is switched off after the AUTO-OFF time has elapsed.

Temperature deactivation is performed independently of the set setback function. The actual temperature flashes in the display and serves as residual-heat indicator. "OFF" appears in the display. A flashing dash appears in the display below 50 °C (150 °F).

The following AUTO-OFF time settings are possible:

- "0 min": AUTO-OFF function is switched off
- "1-999 min": AUTO-OFF time, individually settable
 1. Select the menu item OFF in Menu 1.
 2. Set the AUTO-OFF setpoint time value with the **UP** or **DOWN** button.
 3. Press the **I** (back) or **II** (forwards) button to switch to the next menu item.

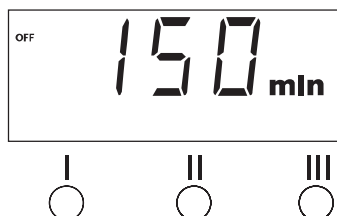

Temperature performance with different settings of the SETBACK and AUTO OFF functions

Settings		Temperature performance without switching holder
SETBACK time [1-99 mins]	OFF time [1-999 mins]	
0	0	Soldering tool remains at the set soldering temperature.
ON		
0	Time	Soldering tool is switched off when not in use ¹⁾ after the OFF time has elapsed.
ON		
Time	0	Soldering tool is controlled down when not in use ¹⁾ to the STANDBY temperature ²⁾ after the SETBACK time has elapsed.
Time	Time	Soldering tool is controlled down when not in use ¹⁾ to the STANDBY temperature ²⁾ after the SETBACK time has elapsed and is switched off after the OFF time has elapsed.
		Temperature performance with switching holder
0	0	Soldering is switched off in the holder ³⁾ .
ON	0	Soldering tool is controlled down in the holder ³⁾ to the STANDBY temperature ²⁾ .
0	Time	Soldering tool is switched off in the holder ³⁾ after the OFF time has elapsed.
ON	Time	Soldering tool is controlled down in the holder ³⁾ to the STANDBY temperature ²⁾ and is switched off after the OFF time has elapsed.
Time	0	Soldering tool is controlled down in the holder ³⁾ to the STANDBY temperature ²⁾ after the SETBACK time has elapsed.
Time	Time	Soldering tool is controlled down in the holder ³⁾ to the STANDBY temperature ²⁾ after the SETBACK time has elapsed and is switched off after the OFF time has elapsed.

¹⁾ Not in use = UP/DOWN buttons not pressed and no temperature drop > 3 °C.

²⁾ STANDBY temperature must be below the set setpoint temperature, otherwise the SETBACK function is inactive.

³⁾ When a switching holder is connected, the soldering tool always remains at the set setpoint temperature outside the holder.

The holder function is activated when the soldering tool is stowed for the first time.

Note Reset of STANDBY and OFF modes:

- without switching holder by pressing the **UP** or **DOWN** button.
- with switching holder by removing the soldering tool from the holder.

Setting the temperature offset

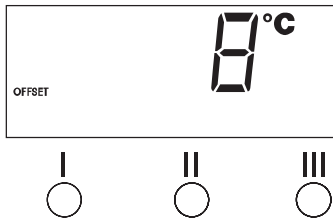

The real soldering-tip temperature can be adapted by entering a temperature offset around $\pm 40\text{ }^{\circ}\text{C}$ ($\pm 72\text{ }^{\circ}\text{F}$).

1. Select the menu item OFFSET in Menu 1.
2. Set the Auto-OFFSET temperature value with the **UP** or **DOWN** button.
3. Press the **I** (back) or **II** (forwards) button to switch to the next menu item.

Setting the window function

It is possible, starting from a set, locked temperature, to set a temperature window of $\pm 99\text{ }^{\circ}\text{C}$ ($\pm 180\text{ }^{\circ}\text{F}$) with the aid of the WINDOW function.

Note To be able to use the WINDOW function, ensure that the soldering station is in the locked state (see "Switching the lock function on/off").

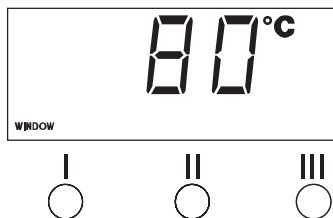

1. Select the menu item WINDOW in Menu 1.
2. Set the WINDOW temperature value with the **UP** or **DOWN** button.
3. Press the **I** (back) or **II** (forwards) button to switch to the next menu item.

Switching the temperature unit

Switching the temperature unit from $^{\circ}\text{C}$ to $^{\circ}\text{F}$ or vice versa.

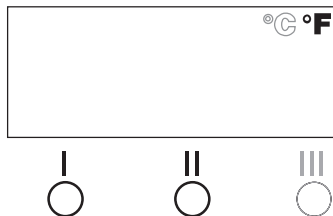

1. Select the menu item $^{\circ}\text{C} / ^{\circ}\text{F}$ in Menu 1.
2. Set the temperature unit with the **UP** or **DOWN** button.
3. Press the **I** (back) or **II** (forwards) button to switch to the next menu item.

Switching the lock function on/off

Once the lock is activated, only the temperature buttons **I**, **II** and **III** can be used on the soldering station. All other settings are disabled until the repair station is unlocked again.

Lock the soldering station:

1. Select the menu item LOCK in Menu 1.
"OFF" appears in the display. The padlock symbol flashes.

Note Pressing the buttons **I** or **II** while "OFF" is displayed results in the menu item being exited without a stored lock code.

2. Set a 3-digit lock code with the **UP** or **DOWN** button.
3. Press and hold button **III** for 5 s.
The code is stored. The padlock symbol is displayed. The station is now locked. The display switches to the main menu.

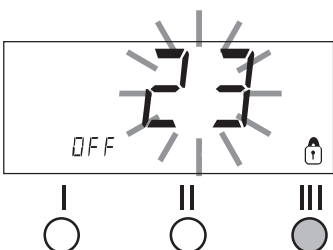

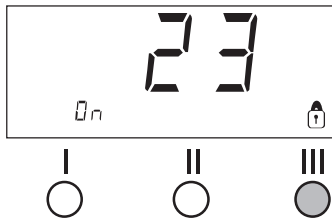

Unlock the soldering station:

1. Select the menu item LOCK in Menu 1.
"ON" appears in the display. The padlock symbol is displayed.
2. Enter the 3-digit lock code with the **UP** or **DOWN** button.
3. Press the **III** button.
The station is now unlocked. The display switches to the main menu.

Note The soldering station can also be unlocked using a decoder list or the reset connector.

7.2 Selecting Menu 2 special functions

Special functions	Navigation
ID	↑ I
FCC	↓ II
AUTO CHANNEL	↓ III
HI / LO CONTROL	EXIT

1. Select the desired channel I, II or III for entering the special functions.
2. Press and hold down the **UP** and **DOWN** buttons simultaneously.
"- 2 -" appears in the display after 4 s.
3. Release the buttons.

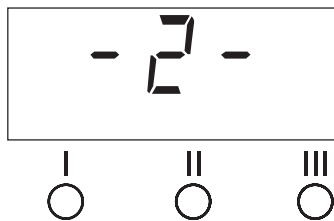

- Selection of the special functions of Menu 2 is activated. The settings can now be made.
- Press the **I** and **II** buttons to select menu items.
 - Press the **III** button to exit the menu again (EXIT).

Setting the station identification (ID code)

When the optional USB port is used, several WD 1 (M) / WD 1000 soldering stations can be activated and remote-controlled to their full operational extent. To this end, each station requires a station identification (ID code) so that it can clearly identified.

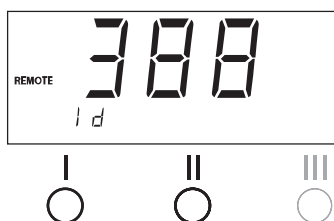

1. Select the menu item REMOTE ID in Menu 2.
2. Enter an ID with the **UP** or **DOWN** button (possible values 0 – 999).
3. Press the **I** (back) or **II** (forwards) button to switch to the next menu item.

Note Press button **III** to exit the menu item without changes (EXIT).

Executing the calibration function (Factory Calibration Check)

With the FCC function you can check the temperature precision of the soldering station and compensate for possible deviations. For this purpose, the soldering-tip temperature must be measured with an external temperature meter and a temperature measuring tip assigned to the soldering tool. The corresponding channel must be selected prior to calibration.

WARNING! Risk of burns



The soldering tool becomes hot during the calibration process. There is a risk of burns from touching the tool.

- ▷ Keep the hot soldering tool well away from flammable objects and do not touch.

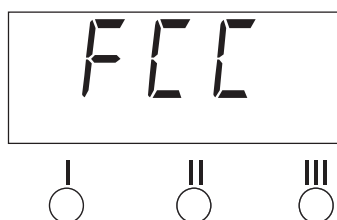

Changing calibration at 100 °C / 212 °F

1. Insert the temperature sensor (0.5 mm) of the external temperature meter into the temperature measuring tip.
2. Select the menu item FCC in Menu 2.
3. Press the **DOWN** button. Calibration point 100 °C / 212 °F is selected.
The soldering tip is now heated to 100 °C / 212 °F.
The control indicator flashes as soon as the temperature is constant.
4. Compare the temperatures indicated by the meter with the indications in the display.
5. Use the **UP** or **DOWN** button to set the difference between the value indicated on the external meter and the value indicated on the soldering station.
Maximum possible temperature adjustment ± 40 °C (± 72 °F).
Example:
Display 100 °C, external meter 98 °C: setting ▲ 2
Display 100 °C, external meter 102 °C: setting ▼ 2

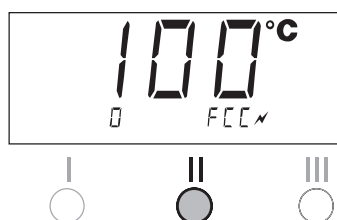

- Note** Press button III to exit the menu item without changes (EXIT).
6. Press button II (Set) to confirm the value.
The temperature deviation is now reset to 0. Calibration at 100 °C / 212 °F is now concluded.
 7. Exit Menu 2 with button III.

Changing calibration at 450 °C / 842 °F

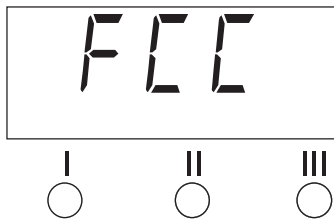

1. Insert the temperature sensor (0.5 mm) of the external temperature meter into the temperature measuring tip.
2. Select the menu item FCC in Menu 2.
3. Press the **UP** button. Calibration point 450 °C / 842 °F is selected. The soldering tip is now heated to 450 °C / 842 °F. The control indicator flashes as soon as the temperature is constant.

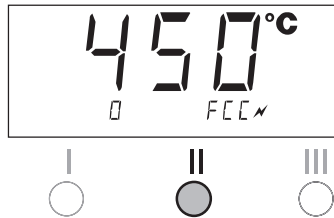

4. Compare the temperatures indicated by the meter with the indications in the display.
5. Use the **UP** or **DOWN** button to set the difference between the value indicated on the external meter and the value indicated on the soldering station. Maximum possible temperature adjustment ± 40 °C (± 72 °F).

Example:

Display 450 °C, external meter 448 °C: setting ▲ 2

Display 450 °C, external meter 452 °C: setting ▼ 2

Note Press button III to exit the menu item without changes (EXIT).

6. Press button II (Set) to confirm the value. The temperature deviation is now reset to 0. Calibration at 450 °C / 842 °F is now concluded.
7. Exit Menu 2 with button III.

Resetting calibration to factory settings

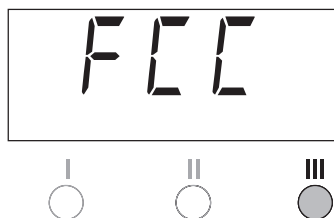

1. Select the menu item FCC in Menu 2.
2. Press and hold button III.
3. Then press the **UP** and **DOWN** buttons simultaneously. "FSE" (Factory Setting Enabled) appears in the display. The soldering station is now reset to the factory settings.
4. Press the I (back) or II (forwards) button to switch to the next menu item.

Setting the control characteristics for the WP 120



- The HI / LO CONTROL function can be used to set the control characteristic of the WP 120, which was set to HI in the factory:
1. Select the menu item HI / LO in Menu 2.
 2. Set the status by pressing the **UP** (HI) or **DOWN** (LO) button.

8 Resetting to factory settings

Resetting the special functions

This function is described under "7.1 Selecting special functions menu 1", "Resetting the special functions to the factory settings" on page 10.

Resetting calibration to factory settings

This function is described under "7.2 Selecting special functions menu 2", "Resetting calibration to factory settings" on page 14.

9 WD 1 (M) / WD 1000 care and maintenance

Dirt and foreign objects accumulated in the joint between the heating element / sensor and the soldering tip or damage to this joint may affect the accuracy of the temperature control.

10 Fault messages and fault elimination

Message/Symptom	Possible cause	Corrective measures
Display: "- - -"	<ul style="list-style-type: none"> – Tool has not been detected – Tool defective 	<ul style="list-style-type: none"> – Check connection of tool to device – Check connected tool
Display: "tip"	Soldering tip of microtool not correctly inserted or defective	<ul style="list-style-type: none"> – Insert soldering tip again – Replacing defective soldering tip
No display function (display off)	No mains supply voltage	<ul style="list-style-type: none"> – Turn on mains power switch – Check mains supply voltage – Check device fuse

11 Accessories

T005 13 841 99	Wool balls for WDC 2
T005 15 125 99	WDC 2 Dry cleaning insert
T005 15 161 99	WDH 10T Switching holder WSP 80/WP 80
T005 15 162 99	WDH 20T Switching holder for WMP
T005 27 028 99	WHP 80 Preheater plate
T005 27 040 99	WSB 80 Soldering bath, 80 W
T005 29 178 99	WSP 80 Soldering set
T005 29 179 99	WMP Soldering set
T005 29 181 99	WP 80 Soldering set, 80 W
T005 29 188 99	LR 82 Soldering set
T005 33 133 99	WTA 50 Desoldering set
T005 87 597 28	Reset connector °C
T005 87 597 27	Reset connector °F
T005 31 185 99	USB Extension module

For WD 1M only

T005 13 173 99	WMRT Desoldering set
T005 27 042 99	WSB 150 Soldering bath, 150 W
T005 29 189 99	WSP 150 Soldering set, 150 W
T005 29 190 99	WMRP Soldering set
T005 29 193 99	WP 120 Soldering iron, 120 W

Please refer to the operating instructions accompanying the individual soldering-bit sets for more information on accessories.



12 Disposal

Dispose of replaced equipment parts, filters or old devices in accordance with the rules and regulations applicable in your country.

13 Warranty

Claims based on defects will fall under the statute of limitations 12 months after delivery to the purchaser of the goods. This shall not apply to rights of recourse of the purchaser according to sections 478, 479 German Civil Code.

We shall assume liability for warranties supplied by us only if the quality guarantee or service warranty has been submitted in writing and using the term "Warranty".

Subject to technical alterations and amendments!

See the updated operating instructions at www.weller-tools.com.

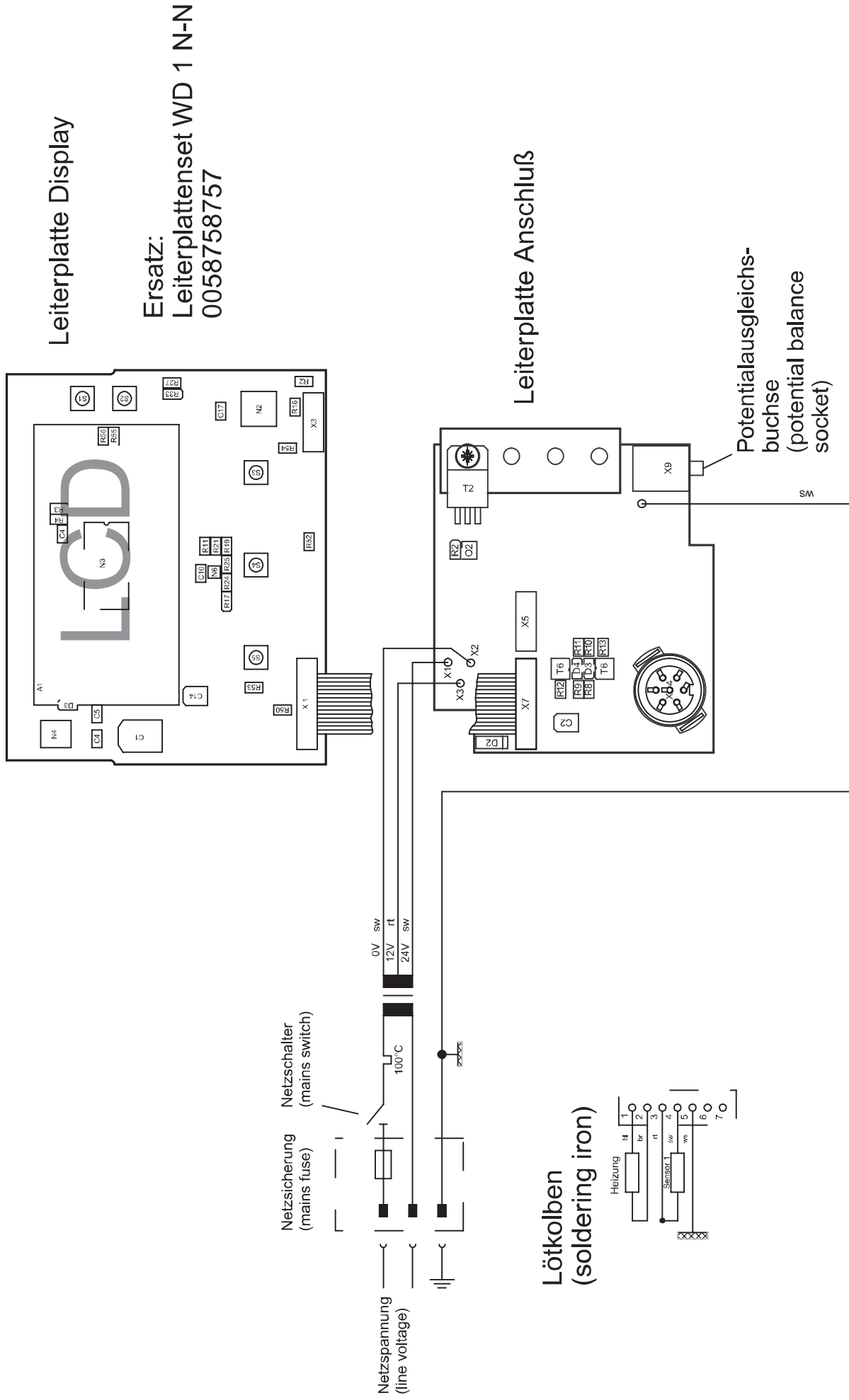

WD 1 / WD 1000 – Exploded Drawing

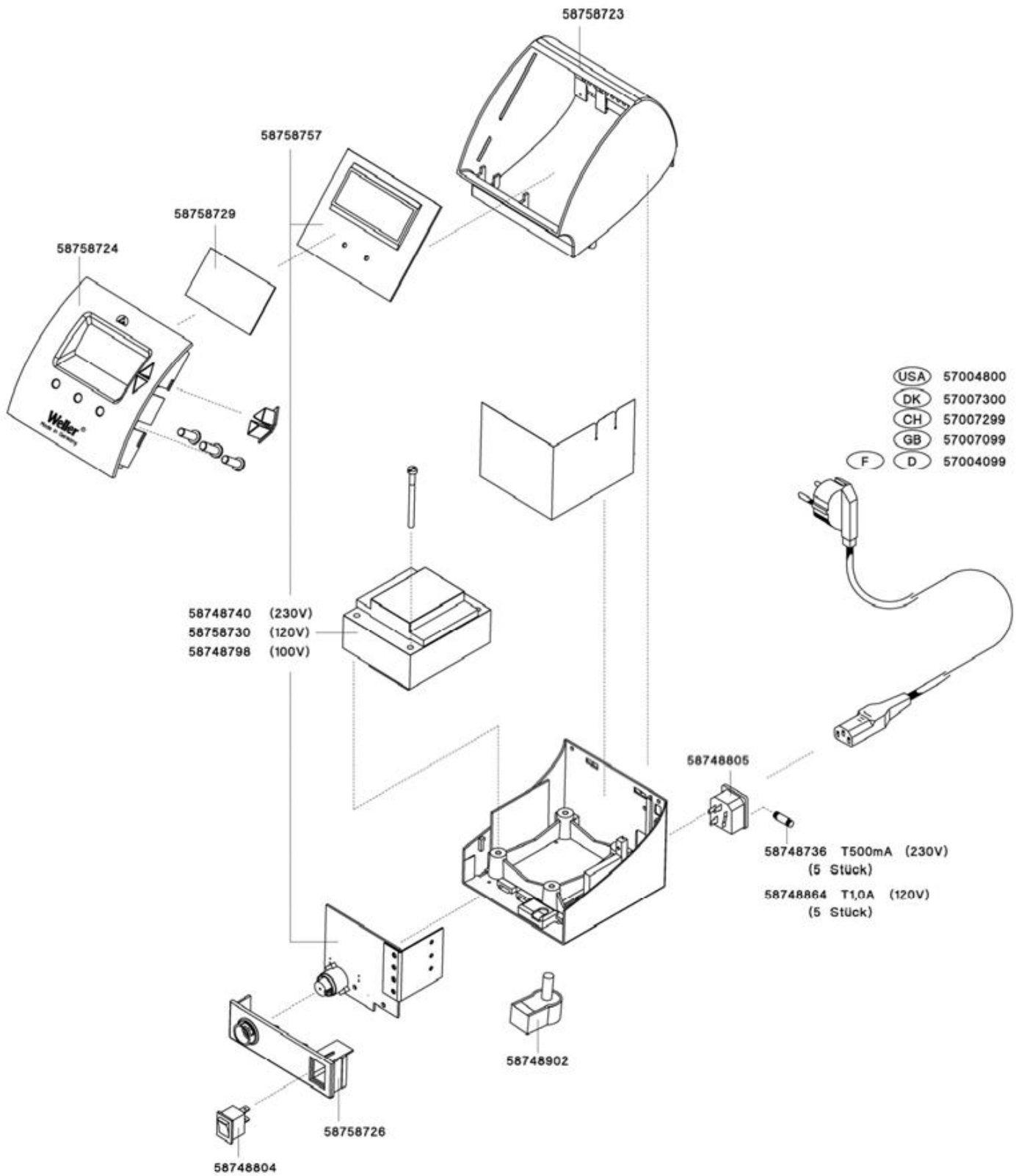

WD 1M / WD 1000

Leiterplatte Display

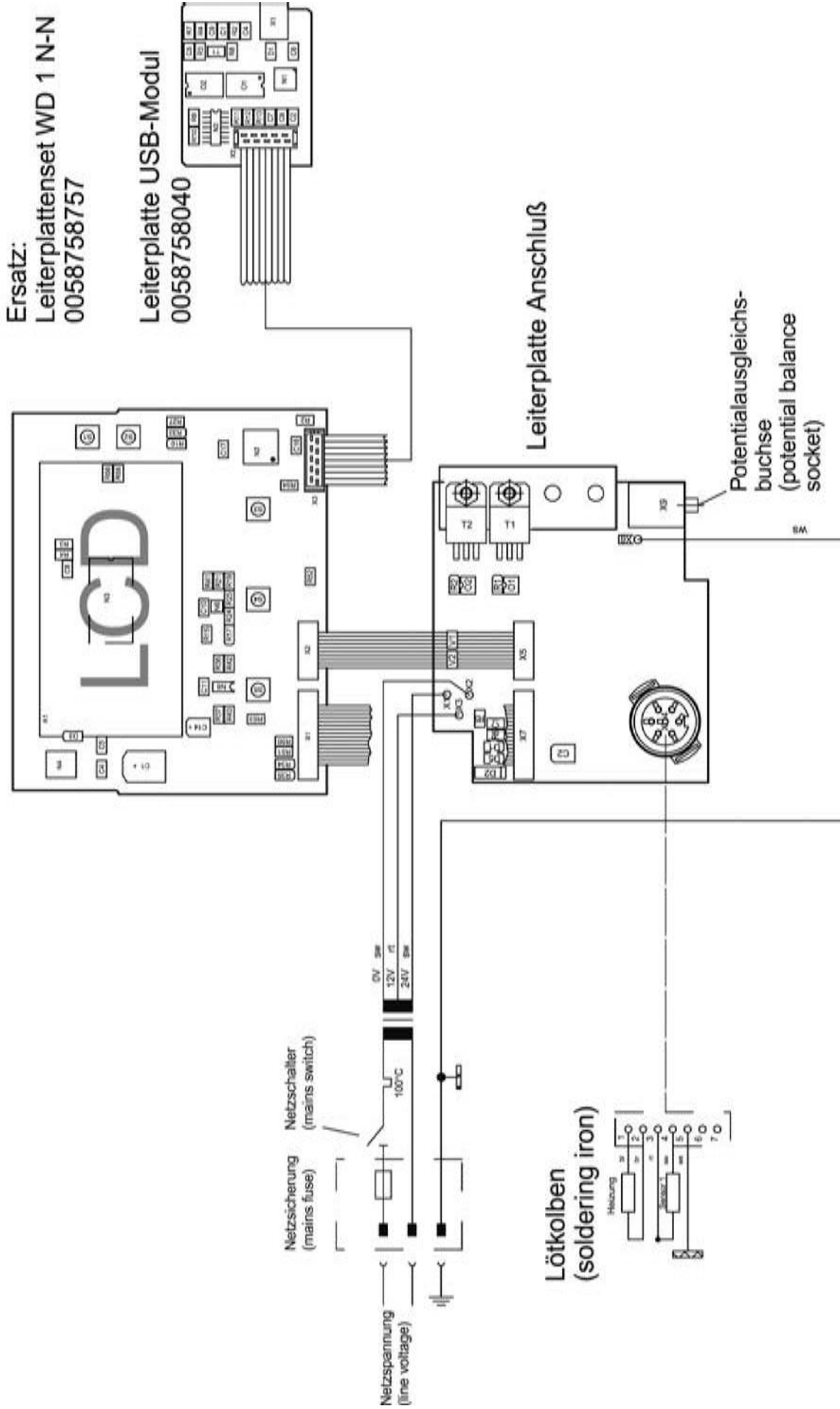

WD 1M / WD 1000 – Exploded Drawing

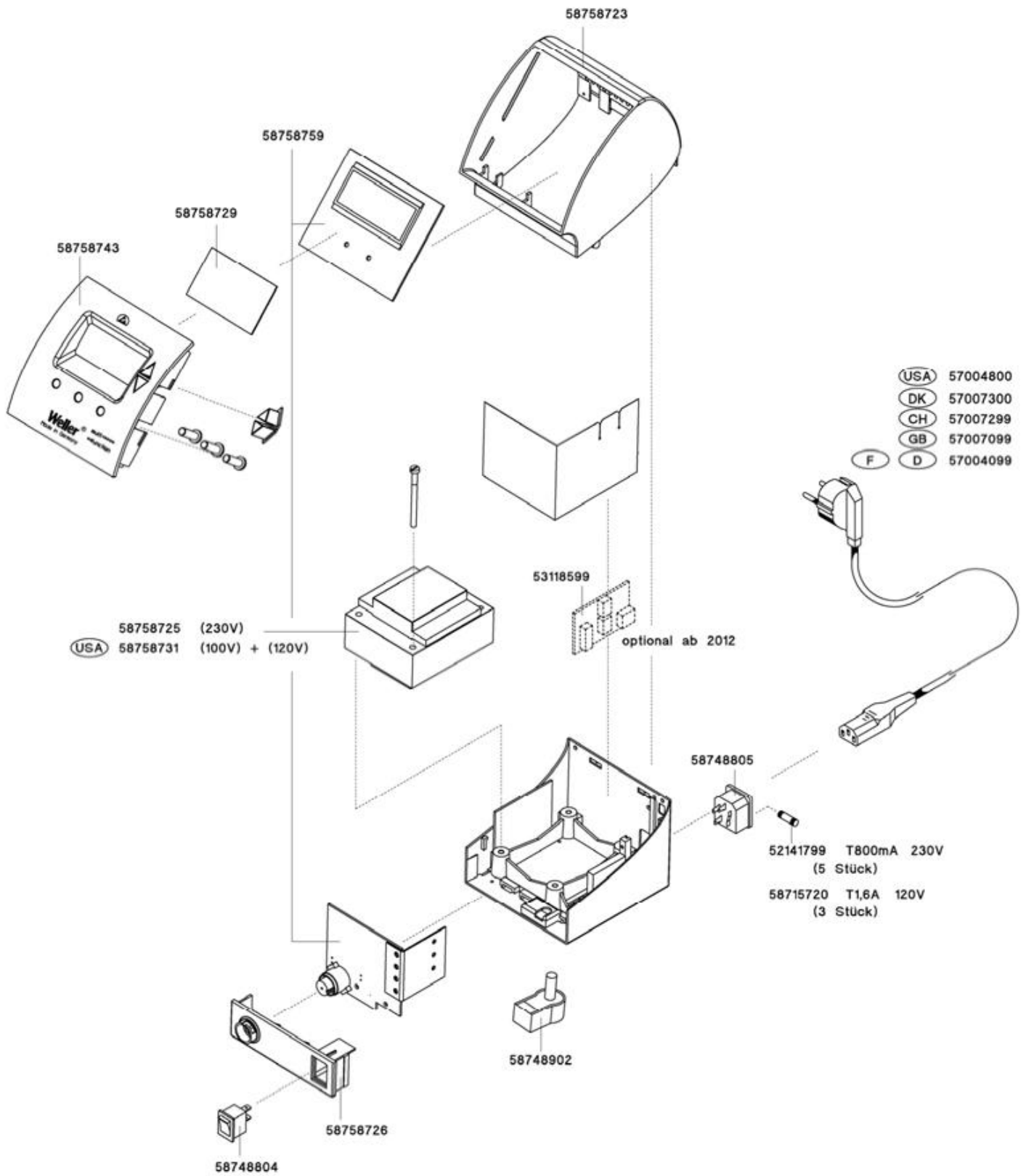

GERMANY**Weller Tools GmbH**

Carl-Benz-Str. 2

74354 Besigheim

Phone: +49 (0) 7143 580-0

Fax: +49 (0) 7143 580-108

GREAT BRITAIN**Apex Tool Group****(UK Operations) Ltd.**4th Floor Pennine House

Washington, Tyne & Wear

NE37 1LY

Phone: +44 (0) 191 419 7700

Fax: +44 (0) 191 417 9421

FRANCE**Apex Tool Group S.N.C.**

25 Av. Maurice Chevalier BP 46

77832 Ozoir-la-Ferrière Cedex

Phone: +33 (0) 1.64.43.22.00

Fax: +33 (0) 1.64.43.21.62

ITALY**Apex Tool S.r.l.**

Viale Europa 80

20090 Cusago (MI)

Phone: +39 (02) 9033101

Fax: +39 (02) 90394231

SWITZERLAND**Apex Tool Switzerland Sàrl**

Rue de la Roselière 12

1401 Yverdon-les-Bains

Phone: +41 (0) 24 426 12 06

Fax: +41 (0) 24 425 09 77

AUSTRALIA**Apex Tool Group**

P.O. Box 366

519 Nurigong Street

Albury, N. S. W. 2640

Phone: +61 (2) 6058-0300

CANADA**Apex Tool Group**

164 Innisfil Street

Barrie Ontario

Canada L4N 3E7

Phone: +1 (905) 455 5200

CHINA**Apex Tool Group**

A-8 building, No. 38 Dongsheng Road,

Heqing Industrial Park, Pudong

Shanghai PRC 201201

Phone: +86 (21) 60880288

USA**Apex Tool Group, LLC**

14600 York Rd. Suite A

Sparks, MS 21152

Phone: +1 (800) 688-8949

Fax: +1 (800) 234-0472

T005 56 869 12 / 04.2013

T005 56 869 11 / 02.2012

www.weller-tools.com**Weller®**