

401H000898

# DSSLF2X04H

## Intelligent Lead Free Soldering Station

### 2 IN 1

## **OPERATION and MAINTENANCE MANUAL**

Thank you for purchasing a lead free soldering station. It is designed for lead free soldering. Please read this manual before operating the unit. Store this manual in a safe, easily accessible place for future reference.

## TABLE OF CONTENTS

Safety Instruction.....	1
□. Summary.....	3
□. Specifications.....	3
III. Setting & Operating the Unit.....	4
3.1 Usages of the Iron Handle Holder.....	4
3.2 Connection.....	4
3.3 Temperature Setting.....	5
3.4 Sound Setting.....	6
3.5 Calibrating the Iron Temperature.....	6
□. Parameter Setting.....	7
4.1 Password Setting.....	7
4.2 Sleeping.....	9
□. Select a Correct Tip.....	10
VI. Use and Maintain.....	10
6.1 Care and Use of the Tip.....	10
6.2 Maintenance.....	11
6.2.1 Inspect and clean the tip.....	11
6.2.2 A de-tinned tip.....	12
6.2.3 To restore a de-tinned tip.....	12
6.2.4 Extending Tip's life.....	12
□. Error Messages.....	13
VIII. Check and Replace the Parts.....	13
8.1 Check and Measure the Soldering Iron.....	13
8.1.1 Check the soldering iron.....	13
8.1.2 Measure the heating element and sensor.....	14
8.1.3 Checking the Heating Element.....	15
8.1.4 Change the Heating Element or the Sensor.....	15
8.1.5 Check the Handle Cord of Soldering Iron.....	15
8.2 Replace the Fuse.....	15
□. Tips.....	16

# Safety Instruction

## **WARNING**

 **WARNING:** Misuse may potentially cause death of, or serious injury to the user.

 **CAUTION:** Misuse may potentially cause injury to the user or physical damage to the objects involved.  
For your own safety, be sure to comply with these precautions.

## **CAUTION**

**When the power is on, the tip temperature is very high. Since mishandling may lead to burns or fire, be sure to comply with the following precautions.**

- Please avoid an abuse of the equipment, use the appliance only in the described way!
- Do not touch the metallic parts near the tip.
- Do not use the product near flammable items.
- Advise other people in the work area that the unit can reach a very high temperature and should be considered potentially dangerous.
- Turn the power off while taking breaks and when finished using the unit.
- Before replacing parts or storing the unit, turn the power off and allow the unit to cool to room temperature.

**To prevent damage to the unit and ensure a safe working environment, be sure to comply with the following precautions.**

- Appliance shall only be used with rated voltage and frequency. (Refer to the trademark back of equipment.)

- Don't use or stop the use if the appliance is damaged, especially the supply cord.
- This machine is equipped with a 3-wires grounding plug and must be plugged into a 3-terminal grounded socket. Do not modify plug or use an ungrounded power socket. If an extension cord is necessary, use only a 3-wire extension cord that provides grounding.
- Do not use the unit for applications other than soldering.
- Do not rap the soldering iron against the work bench to shake off residual solder, or otherwise subject the iron to severe shocks.
- Do not modify the unit.
- Use only genuine replacement parts.
- Do not wet the unit or use and disconnect the unit when your hands are wet and without to force the supply cord.
- The soldering process will produce smoke, so make sure the area is well ventilated.
- While using the unit, don't do anything which may cause bodily harm or physical damage.
- Children don't recognize the risks of electrical appliances. Therefore use or keep the appliance only under supervision of adults and out of the reach from children.

## □. Summary

This unit is an intelligent lead free soldering with two workstations. It adopts LED display and digital calibration, password protection, rapid and convenience. The temperature induction is very exact and sensitive, the speed of heating and recovery of temperature is very fast. So it is one of the most perfect tools for lead free soldering.

## II. Specifications

<b>Station Name</b>	<b>DSSLF2X04H</b>
Power	90W *2
Temperature range	80°C~480°C
Max Ambient Temperature	40°C
Temperature Stability	±2°C/Without air flow and no load
Housing Material	Aluminum
Outer Dimension	160 (L) ×130 (W) ×100 (H) mm
Weight	1.8kg
<b>Handle Name</b>	<b>DSPLF04A</b>
Heating Element	Electromagnetic heater
Tip to Ground Resistance	<2Ω (DC)
Tip to Ground Potential	<2mv
Power Cord Assembly	1.2m

- The tip temperature is measured using 191/192 series thermometer.
- Specifications and design subject will be changed without notice.

3. Install a new fuse and put the fuse holder back in place.

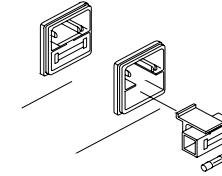

## □. Tips

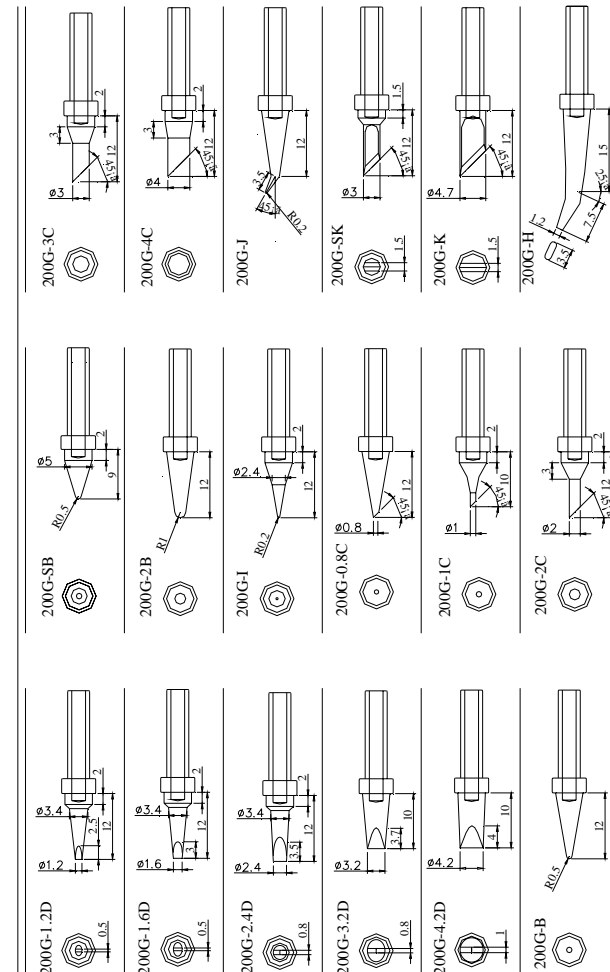

### 8.1.3 Checking the Heating Element

Measure the heating element when it comes back to room temperature:

1. Resistance value of heating element (White and Black wire) under  $4\Omega$ .
2. Resistance value of sensor (Red and Grounding wire) under  $10\Omega$ .
3. If the resistance value isn't normal, replace the heating element.

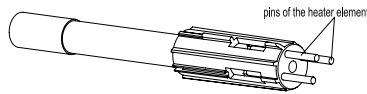

### 8.1.4 Change the Heating Element or the Sensor

After replacing the heating element:

1. Measure the resistance value between ①pins 4 & 2 or 3, ②pins 5 & 2 or 3, ③ pins 6 & 2 or 3, ④pins 6 & 4 or 5. If it is not  $\infty$ , the heating element and sensor are touching. This will damage the P.W.B.
2. Measure the resistance value "a", "b" and "c" to confirm that the leads are not twisted and that the grounding wire is properly connected.
3. Ensure the pins have inserted into the end.

### 8.1.5 Check the Handle Cord of Soldering Iron

Check the resistance between the pins of the plug and the wires on the terminal. The value should be 0. If it is greater than 0 or is  $\infty$ , the cord should be replaced.

Pin1: Null	Pin2: Red
Pin3: Blue & Green (ground)	Pin4: Shielded Conductor
Pin5: Lining of the Shielded Conductor (White)	Pin6: White

## 8.2 Replace the Fuse

1. Turn power switch off and take out the fuse holder at the power socket.
2. Open the fuse holder and take out the broken fuse.

## III. Setting & Operating the Unit

**⚠CAUTION:** Page 15

**Before setting, please check whether the voltage accords with the rated voltage on the unit's nameplate.**

### 3.1 Usages of the Iron Handle Holder

**⚠CAUTION:**

- It can clean the iron tip by the clean sponge or soft metal ball.
  - The sponge is compressed. It will swell when moistened with water. Before using the unit, dampen the sponge with the water and squeeze it dry. Failure to do so may result in damage to the Soldering tip.
  - During the work, add water to the holder base if the sponge becomes dry.
1. Dampen the small cleaning sponge with water and then squeeze it dry. Place it in the iron holder base.
  2. Add water to iron holder base. The small sponge will absorb water to keep the large sponge above it wet.
  3. The large sponge may be used alone (without small sponge & water). Dampen the large cleaning sponge and place it on the iron holder base.
  4. Except the clean sponge, it also can clean the iron tip by the clean metal ball which is made of soft brass wires.

### 3.2 Connection

**⚠CAUTION:**

**Be sure to turn off the power switch before connecting or**

**disconnecting the soldering iron. Failure to do so may result in damage to the soldering station.**

1. Connect the cord assembly to receptacle.
2. Place the soldering iron handle in the iron holder.
3. Be sure to ground the unit. One end of the unit connects with the grounding hole at the back of the unit, and the other end connects with the earth.
4. Plug the power cord into a power supply.
5. Turn on the power switch.
6. The heater point (the radix point on the 1's right side) flickers when the temperature has stabilized.



### 3.3 Temperature Setting

**⚠CAUTION:**

**Make sure the temperature of the station can be adjusted (Password is right or the password is initial “000”). While setting the temperature normally, the heating element is off.**

**⚠WARNING:**

**The heater and soldering iron tip will be seriously oxidized or damaged when working with a high temperature. So please try to operate with a lower temperature if possible.**

**Temperature rising:**

Press “▲” key directly. If so, the setting temperature will raise 1°C and the display window will display the set temperature. When loosen the “▲” key, the display window will delay the set temperature about 2 seconds. If within 2 seconds, press the “▲” key again, the setting temperature will raise 1°C again. If press the “▲” key and not loose at least 1 second, the setting temperature will

rise rapidly. Till the needed temperature reaches, then loose the “▲” key.

1. If the values of ‘a’ and ‘b’ are different from the values in the following table, replace the heating element or sensor or cord assembly. Refer to the following steps. Page 5
2. If the value of ‘c’ is over the below value, remove lightly the oxidation in the joint part of the tip and the heat element with sandpaper or steel wool.

a.	Between pins 4&5 (Heating Element)	Under 4 Ω (Normal)
b.	Between pins 2&3 (Sensor)	Under 10 Ω (Normal)
c.	Between pins 3& Tip	Under 2 Ω

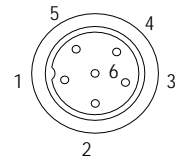

**NOTE:** When checking b and c items in the table, the soldering iron must be equipped with tip.

### 8.1.2 Measure the Heating Element and Sensor

1. Pull out the iron tip and the tip encloser towards the tip, the iron tip and the iron tip encloser □ are in together.
2. Pull out the heating element □ towards the iron tip of the iron handle □.
3. Push the handle cord (12) lightly forwards and pull the sensor □, PCB for line connection □ and handle cord out of the iron handle □ (towards the tip of the handle).

**NOTE:** Do not use metal tools such as pliers to remove tip or tip encloser from the iron handle.

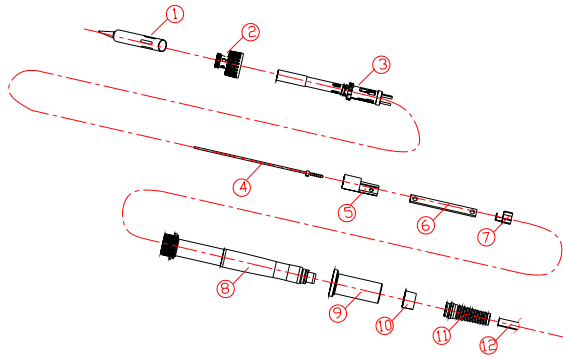

4. Do not use the tip as a prying tool. Bending the tip can cause the plating to crack, shortening tip life.
5. Use the minimum activation flux necessary to do the job. Higher activation flux is more corrosive to the tip plating.
6. Extend tip life by switch the system off when not in use.
7. Don't apply pressure to the tip. More pressure does not equal more heat. To improve heat transfer, use solder to form a thermal bridge between the tip and the solder joint.

Page 14

## VII. Error Messages

Various error messages will be displayed when there is something wrong with the unit.

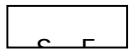

Sensor error: If there is a failure in the sensor or anywhere in the sensor circuit, "S-E" will be displayed and power to the soldering iron will be cut off.

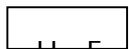

Heater error: If power can't be sent to soldering iron, the display window will show "H-E". This indicates the possibility of a heater malfunction.

## VIII. Check and Replace the Parts

### 8.1 Check and Measure the Soldering Iron

When there is something wrong with soldering iron, you can check and test it. If it is broken, replace the broken element.

#### 8.1.1 Check the Soldering Iron

Pull out the plug and measure the resistance value between the pins of the connecting plug when the heating element cooling down to the room temperature.

#### Temperature dropping:

Press "▼" key directly. If so, the setting temperature will drop 1°C and the display window will display the set temperature. When loose the "▼" key, the display window will delay the set temperature about 2 seconds. If 2 seconds later, press the "▼" key again, the setting temperature will drop 1°C again. If press the "▼" key and not loose at least 1 second, the setting temperature will drop rapidly. Till the needed temperature reaches, then loose the "▼" key.

Page 13

### 3.4 Sound Setting

1. In the working state and the inputting password is right or is "000", press the four "▲" and "▼" buttons at the same time to turn on or off the sound.
2. After turning on the sound, the unit will sound "di-di" when click the buttons.
3. After turning on the sound, the unit will sound (with alarming work state) when the setting temperature is high than the real temperature 150°C during the heating or the setting temperature is less than the real temperature 80°C during the cooling.
4. After turning off the sound, the unit will not sound when clicking the buttons or temperature up-limit or down-limit sound.



## 3.5 Calibrating the Iron Temperature

The Soldering Iron should be recalibrated after changing the iron or replacing the heating element or tip.

Method of recalibrating temperature: Use the thermometer to calibrate.

1. Set the iron's temperature to a certain value.
2. When the temperature stabilizes, measure the tip's temperature with thermometer and write down the reading.
3. Press the "▲" and "▼" buttons not loose and then press "ON/OFF" button simultaneously, the soldering iron enters into the calibration mode.
4. At the moment, the digit of LED display temperature is flashing. Press the "▲" or "▼" button to input the value on the thermometer and then press the "ON/OFF" button about 1 second. Here, the calibration operation has been finished.
5. If the temperature still has deflection, you can repeat calibration in accordance with above steps.

### NOTE:

- Recommend using the 191/192 thermometer for measuring the tip temperature.
- If the unit is locked by password, it will not be able to calibrate and you must input the right password.

## □. Parameter Setting



The station has the following parameters setting. Before adjusting the parameter of the unit, it needs to input the right password.

### 4.1 Password Setting

The unit's password is one and only and the initial password is "000". The

setting temperature is admitted in this status. If need to restrict the setting temperature, the password must be changed and turn off the unit, then turn on.

### ● Enter into setting password

1. Turn off the power switch, Press and hold the "▲" and "▼" buttons simultaneously, then turn on the power switch.
2. Continue holding down the "▲" and "▼" buttons until the display shows "  ".
3. When the LED shows  , the unit is in parameter setting mode.

## 6.2.2 A de-tinned tip

Page 7

### 1. Why a "detinned" tip fails to work?

*A detinned tip is one which cannot wet with solder. This exposes the plating to oxidation and degrades the heat transfer efficiency of the tip.*

### 2. The detinning is caused by:

- (1) Failure to keep the tip covered with fresh solder while not in use.
- (2) High tip temperatures.
- (3) Insufficient melting in soldering operations.
- (4) Wiping the tip on dirty or dry sponges and rags. (Always use a clean, wet, industrial grade, sulfur-free sponge.)
- (5) Impurities in the solder, iron plating, or on the surfaces to be soldered.

## 6.2.3 To restore a de-tinned tip

1. Remove the tip from the solder handle and wait the tip to cool down.
2. Remove dirt and oxides from the tinned area of tip with 80-grit abrasive polyurethane foam stock or a 100-grit emery cloth.
3. Wrap rosin core solder ( $\phi 0.8\text{mm}$  or larger) around the newly exposed iron surface, insert the tip into handle, and turn on the power switch.

**NOTE: the de-tinned tips are preventable by proper daily care!**

## 6.2.4 Extending Tip's life

1. Tin the tip before and after each use. This protects the tip from oxidizing, and prolongs tip life.
2. Do the job at the lowest temperature. Lower temperatures decrease tip oxidation and are easier on the components being joined.
3. Use fine point tips only when necessary. The plating on fine precision tips is less durable than the plating on blunter tips.

## Cleaning

Clean the tip regularly with a cleaning sponge, as oxides and carbides from the solder and flux can form impurities on the tip. These impurities can result in defective joints or reduce the tip's heat conductivity.

When using the soldering iron continuously, be sure to loosen the tip and remove all oxides least once a week.

This helps prevent reduction of the tip temperature.

## When not in use

Never leave the soldering iron sitting at high temperature for long periods of time, as the tip's solder plating will be covered with oxide, which can greatly reduce the tip's heat conductivity.

## After use

Wipe the tip and coat it with fresh solder. This helps to prevent tip oxidation.

## 6.2 Maintenance

### 6.2.1 Inspect and Clean the Tip

**⚠ CAUTION: Never file the tip to remove oxide.**

1. Set the temperature to 250°C.
2. When the temperature stabilizes, clean the tip with the cleaning sponge and check the condition of the tip.
3. If there is black oxide on the solder-plated portion of the tip, apply new solder (containing flux) and wipe the tip on the cleaning sponge. Repeat until the oxide is completely removed. Coat with new solder. The solder protects the tip from oxidation and prolongs the life of the tip.
4. If the tip is deformed or heavily eroded, replace it with a new one.

#### ● Input previous password

4. Press the "ON/OFF" button, the LED shows "----", and the leftmost digit (the 100's digit) in the LED will flash. This indicates the iron is in password setting mode and the 100's digit can be adjusted. Use the "▲" or "▼" button to change displayed value. Set the password value in the same way described in "temperature setting".

After selecting the password of three digit, press the "ON/OFF" button.



#### ● The input password is error

5. If the iron enters into normal work state after display shows the current setting temperature for two seconds, this indicates the input password is error, and the temperature setting can't be done.

#### ● The input password is correct

6. If the display window shows  , this indicates the inputting password is correct. After displaying about 4 seconds, the iron comes into normal work state, and the temperature setting and parameter setting will be admitted.

● **Input new password**

7. When display window is showing  , press the “ ON/OFF” button, and shows  , it indicates the iron comes into inputting new password state. Press “▲” or “▼” button to change displayed value. See “temperature setting”.

● **Repeat the new password**

8. When three digits are selected, press “ON/OFF” button, the display window shows  , again. Now input the new password once again. Repeat the same steps.

9. If the latest two passwords are the same, pressing “ON/OFF” button will modify the password successfully. The new password is stored into the memory. Page 8

10. If the latest two passwords are not the same, pressing “ON/OFF” button, and the display window shows  , it needs to rewrite new password. The changing of password is successful until the latest two passwords are the same.

**NOTE:**

- *The word of password is 0 to 9, ten figures. If not, the input password is invalid.*
- *Because the password of the two work stations is only one, after setting the password of one station, the parameter setting of other station is locked too.*

## 4.2 Sleeping

1. After inputting right password and the display will show “ ”. Press the “▲” and “▼” buttons at the same time into the sleeping time setting.
2. And then press the “▲” or “▼” button to select the sleeping time. The default sleeping time is 20minutes.

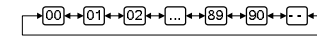

3. **If sleeping time is “00”**: it will sleep at once after placing the handle on the holder.
4. **If sleeping time is among “01~90”**: and the soldering iron is not used for 01-90 minutes, the power to the heating element will be decreased, and the display shows  . This state is sleeping mode.
5. **If select “-”**, the unit will not sleep.
6. When the iron is in sleeping mode, the tip temperature will decrease to 200℃ (if the set temperature is more than or equal to 200℃) or 50℃ (if the set temperature is less than 200℃) and remain the temperature until resuming the iron.
7. If the soldering iron is not resumed more than 60 minutes after it comes to sleeping, the power supply will be shut off automatically, and the display window will not show anything.
8. To resume soldering, there are several ways as follows:
  - (1) Turn off the power switch, and then turn on again.
  - (2) Take up the iron hand of the sleeping station.
  - (3) Click any button among the buttons “▲”, “▼” and “ON/OFF”.

### . Select a Correct Tip

1. Select a tip that maximizes contact area between the tip and solder joint. Maximizing contact area gives the most efficient heat transfer, allowing operators to produce high quality solder joints quickly.

2. Select a tip that allows good access to the solder joint. Shorter tip lengths allow more precise control. Longer or angled may be needed for soldering densely populated boards.

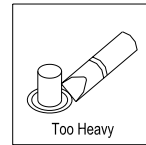
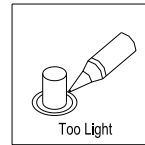
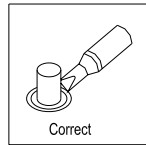

## VI. Use and Maintain

### 6.1 Care and Use of the Tip

#### **Tip's temperature**

High soldering temperatures can degrade the tip. Use the lowest possible soldering temperature. The excellent thermal recovery characteristics ensure efficient and effective soldering event at low temperatures. This also protects the sensitive components from thermal damage.