

DSF-73E

Motorized Solder Wire Feeder

Instruction Manual

Thank you for purchasing the solder wire feeder. Please read this manual before operating the unit. Store this manual in a safe, easily accessible place for future reference.

SECTION I Summary

The unit is an automatic motorized solder wire feeder. It is suitable for variety of soldering stations and soldering irons. Only need one hand to operate and it is easy to operate. With step motor, the feeding speed and time, returning length and feeding interval time are all adjustable and steady, perfect soldering effect and high efficiency.

SECTION II Specification

Power Consumption	20W
Motor	Step Motor
Feeding Speed	2.7mm/s~27mm/s
Feeding Interval Time	0~2.7s
Returning Length	About 0~25mm
Feeding Mode	Auto. (1~9) / Manual (0)
Dia. of the solder wire	1.4/1.6/1.8/2.0 (mm)
Weight of solder wire usable	≤1Kg (roll)

NOTE: In order to choose feeder tube and wire diameter ring exactly, please mark the soldering iron type and wire diameter when purchasing the unit.

SECTION III Characteristics

- Automatic self-feeder that can match a variety of soldering stations and soldering irons.
- Auto and manual controlled feeding can be optional. It is easy to operate and only with one hand.
- Feeding speed, time and interval time are all adjustable, further more it is designed with returning function to reduce solder wire consumption.
- Both of Pedal switch and Manual switch can be used.
- ESD safe by design to avoid damaging the sensible electronic elements because of the static.

SECTION IV Panel Picture

Page 1

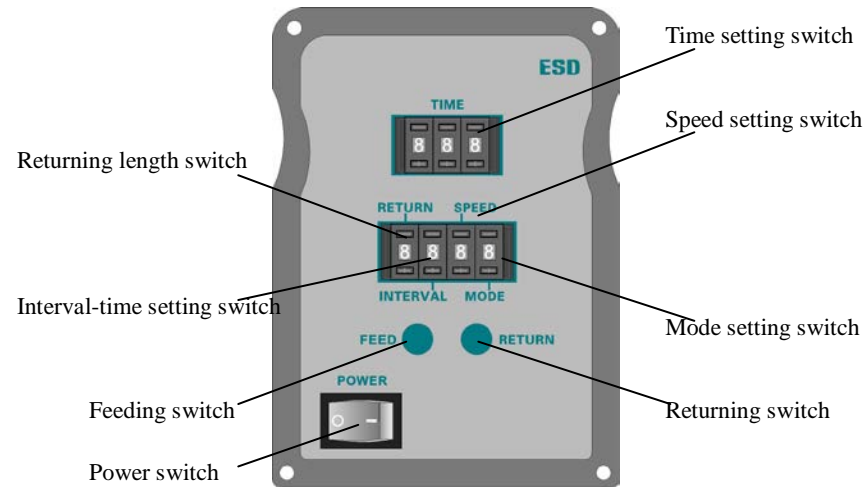

Page 2

SECTION V Installation

Before installation, please check the parts and make sure whether the power supply voltage accords with the nameplate.

1. Install feeder tube assembly

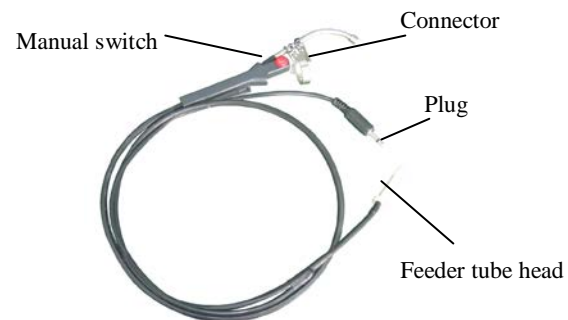

6. Feeding Pressure Setting

When the solder wire cannot be sent out automatically because of the inadequate feeding pressure, you can clockwise adjust the pressure adjusting screw on the top of unit to increase feeding pressure.

When the solder wire is twisted because of too strong feeding pressure, you can adjust the pressure adjusting screw anticlockwise.

SECTION VII Operations

1. It can press the key "FEED" or "RETURN" to adjust the length of the solder wire.

FEED: Click the "FEED" key, the system will feed the solder wire once. If pressing the "FEED" key and not loosen, it will feed the solder wire continually.

RETURN: Click the "RETURN" key, the solder wire will return once about 3mm.

NOTE: During the working state of mode 0~9, the system will not run the process sending from the "FEED" and "RETURN" keys.

2. Do corresponding operations in accordance with the chosen Feeding Mode.

1) Manual — The Mode switch is set as 0

Turn on power switch. Step on Pedal Switch or press the red Touch Switch, and the unit works. After loosing it, returning once and then stop working.

Feeding Time and Feeding Interval and Feeding Mode are all useless when the Feeding Mode is set as manual.

2) Auto — The Mode switch is set as during 1~9

Turn on Power Switch. The unit will work according to the setting parameters when stepping on pedal switch or pressing Touch Switch once. All functions are useful.

Unscrew the fixing screw on the top cover of unit, insert the feeder tube head of the feeder tube into the directional fixing tube of the feeder tube head, and then tighten the screw.

Insert the plug into the jack on the back cover of the unit.

2. Install the solder wire

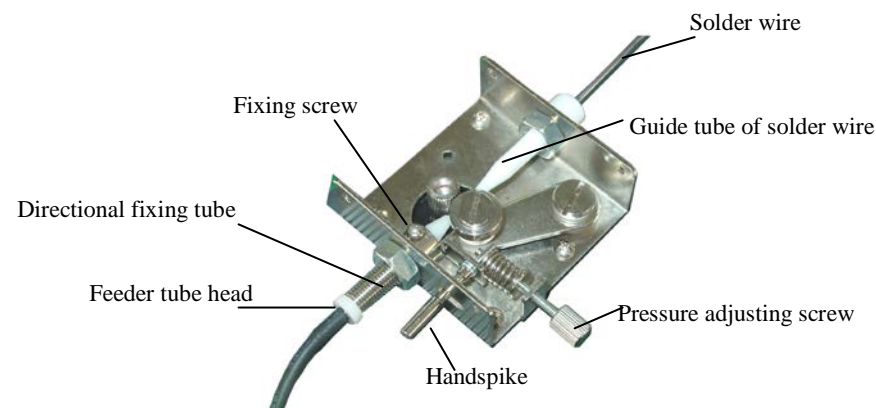

- (1) Pull the solder wire axis through the framework of solder wire and place it to the solder wire holder at the back of unit. Make the notch on each side of solder wire axis lock into the solder wire holder.
- (2) Pull out the solder wire head and insert it into the guide tube of solder wire behind the top. For the solder wire coming into the feeder tube head easily, push handspike to widen the gap between the two running gear wheels.
- (3) Set the Feeding Mode as manual "0", and insert power plug and turn on power switch "POWER". Make the Feeder Tube as straight as possibly, press down the manual switch (the red Touch Switch) until the solder wire is sent out.

3. Install Soldering Iron

Take down connector plugs of the soldering iron from the soldering station

and then install the feeder tube connector on the soldering iron.

- (1) Firstly, loosen the fixing screws of the feeder tube connector.
- (2) And then install the handle into the feeder tube connector. The connector is installed in the notches on the top of the handle.
- (3) After that, screw down the fixing screws on the connector. Turn the connector to adjust the combined location of between the feeder tube and the soldering tip, and at last connect the soldering iron to soldering station.

⚠ Note:

- **When pressing down the red touch switch (Manual switch), if the solder wire cannot be sent out automatically, it needs to adjust the feeding pressure—pressure adjusting screw (Refer to parameter setting).**
- **The feeder tube cannot be bended overly because the solder wire may be blocked.**
- **When the unit is working, the soldering tip's temperature is very high, please be careful, not to be scalded.**
- **Make sure the power voltage is according with the working voltage of the unit.**

SECTION VI Set Parameters

Parameter is set by digital switch on the panel. Press “+” button on the digital switch and the match digit will increase one. Similarly, press “-” button, and the match digit will decrease one.

1. TIME — Feeding Time Setting

Press the feeding time switch “TIME” to set the suitable digit in accordance with working demand. Feeding Time is designed with three digits. 000 to 999 denotes the feeding time is about 0.15mm~150mm.

Example: When the digit is set as 000, the feeding time (feeding length) is 0.15mm. When the digit is set as 001, the feeding time (feeding length) is about 0.3mm. When it is set as 999, the feeding time is longest and about 150mm.

2. RETURN — Returning Length Setting

Press the returning length switch “RETURN” to set the suitable digit in accordance with working demand. Returning length is designed with one digit.

0 to 9 denotes the returning length is about 0~25mm (returning time is about 0~0.9s). If the “RETURN” is not as “0”, the solder wire will return every feeding.

Example: When the digit is set as 0, the returning length is 0mm. When the digit is set as 1, the returning length is about 2.8mm (the returning time is about 0.1s).When the digit is set as 9, the returning length is about 25mm(the returning time is about 0.9s).

3. INTERVAL — Feeding Interval Time Setting

Press the feeding interval time switch “INTERVAL” to set the suitable digit in accordance with working demand. Feeding Interval Time means the interval time between every feeding when the automatic feeding is over two times. Feeding Interval Time is designed with one digit.

0 to 9 denotes the interval time is about 0~2.7seconds.

Example: When the digit is set as 0, which means the unit will feed solder wire continually without stop. When the digit is set as 1, the interval time is about 0.3second. When the digit is set as 2, the interval time is about 0.6second. When it is set as 9, the interval time is longest with about 2.7seconds.

4. SPEED — Feeding Speed Setting

Press the feeding speed switch “SPEED” to set the suitable digit in accordance with working demand. Feeding speed is designed with one digit. 0~9 denotes the feeding speed is about 2.7mm/s~27mm/s.

Example: When the digit is set as 0, the speed is slowest with about 2.7mm/s. When it is set as 9, the speed is fastest with about 27mm/s.

5. MODE---Feeding Mode Setting

Press the feeding mode switch “MODE” to choose suitable digit. Feeding Mode is designed with one digit and the setting method is the same as above. The digital match function as followings:

0: Manual Feeding--- the manual feeding is control by the manual switch. The solder wire will not stop feeding until loosen the manual switch.

- | | |
|-----------------------------|-----------------------------|
| 1: Auto Feeding one time | 2: Auto Feeding two times |
| 3: Auto Feeding three times | 4: Auto Feeding four times |
| 5: Auto Feeding five times | 6: Auto Feeding six times |
| 7: Auto Feeding seven times | 8: Auto Feeding eight times |
| 9: Auto Feeding nine times | |

After each feeding, the solder wire will return.

