

Desoldering Station

DDS01

Instruction Manual

Thank you for purchasing this desoldering tool. Please read manual carefully before using. Store this manual in a safe, easily accessible place for future reference.

I 、 Specification

In this instruction manual, **WARNING** and **CAUTION** are defined as follows

WARNING: Misuse may potentially cause death of, or serious injury to the user.

CAUTION: Misuse may potentially cause injury to the user or physical damage to the objects involved.

For your own safety ,be sure to comply with these precautions.

Specification

Power of the pump	12V/2A
Power of heating	90W/36VAC 400KHz
Temperature of nozzle	200°C~450°C (See the working mode table)
Pump	Diaphragm pump
Vacuum suction	600mmHG
Nozzle to ground resistance	Less than 2Ω
Nozzle to ground potential	Less than 2mV
Dimension	105 (W) × 250 (D) × 165 (H)mm
Weight	4.8Kg (With iron holder and power cord)

II 、 Part Names

1. Desoldering Gun

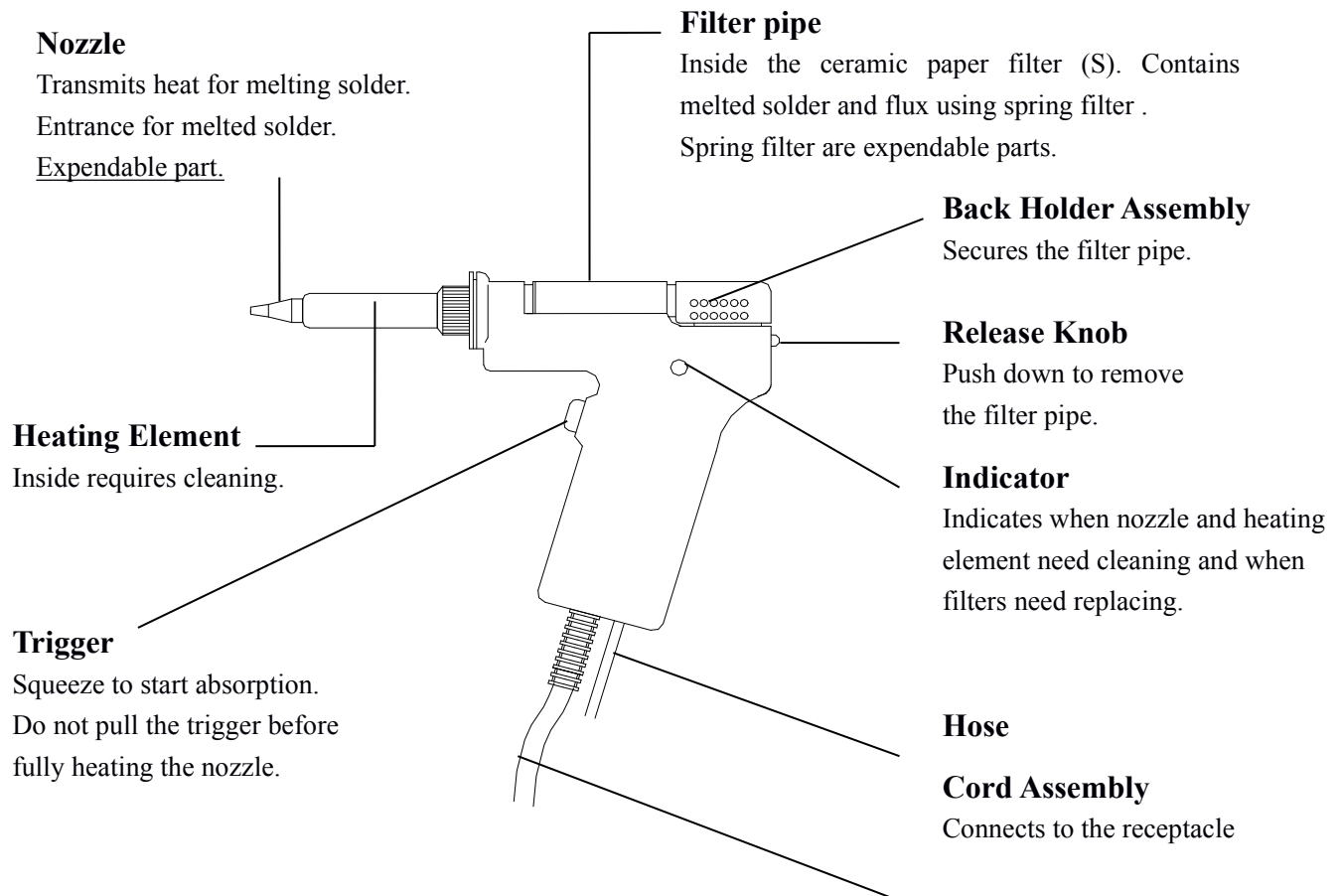

2. Unit

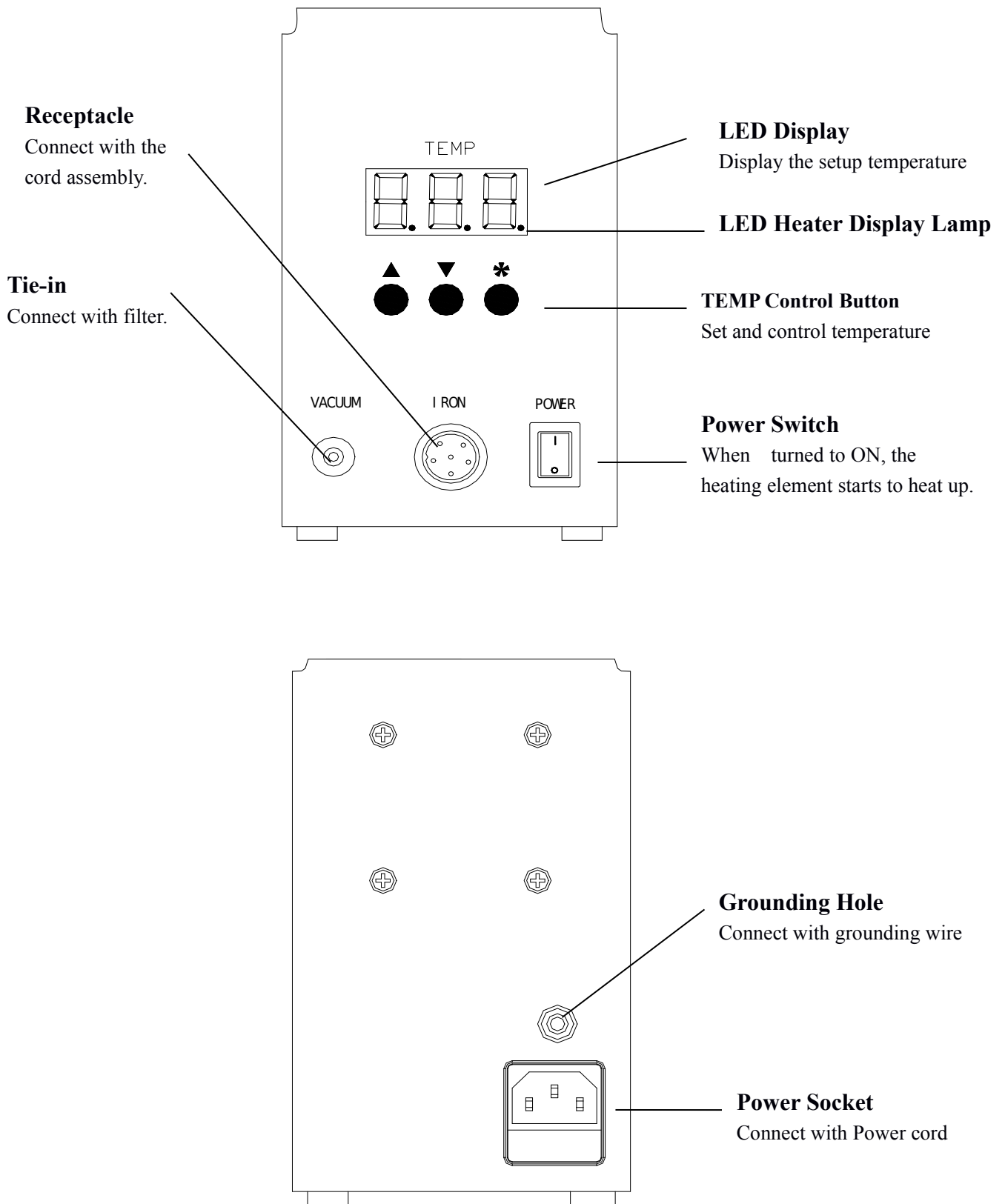

III、 Installation and Operation

▽ CAUTION : Before setting, please check whether the voltage accords with the rated voltage on the unit's nameplate.

1. Iron Holder and Sponge

▽ CAUTION: The sponge is compressed. It will swell when moistened with water. Water and squeeze it dry. Failure to do so may result in damage to the nozzle.

1. Take out the desoldering gun and put it in the iron holder.
2. Dampen the cleaning sponge with water and then squeeze it dry, Be sure to remove the round portion of the sponge and place it in the iron holder.

2. Connections

▽ CAUTION: Be sure to turn off the power switch before connecting or disconnecting the cord assembly and the power plug. Failure to do so may damage the P.W.B.

1. Connect the metal plug of cord assembly to the receptacle (marked "IRON") .

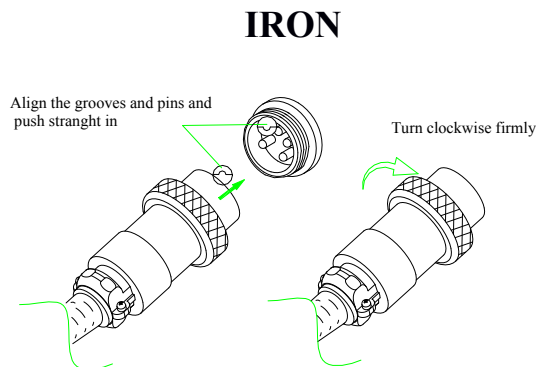

2. Connect the external filter to the tie-in's hose (marked "VACUUM") in accordance with the mark on the external filter, need to insert fully, and connect the other side of filter to desoldering gun's hose.

▽ CAUTION: The external filter have connection orientation and connecting according to mark, otherwise affect suction.

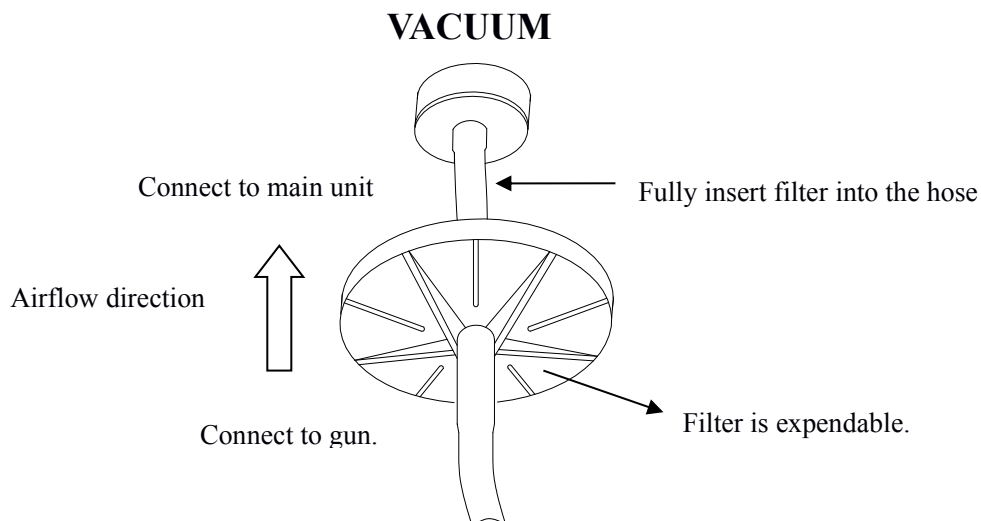

3. Plug the power cord.
4. Turn on the power switch and LED display is light, the desoldering gun begins to heat up.
The heater lamp flickers when the temperature has stabilized.

CAUTION: After turning the power switch to ON, wait 3 minutes before beginning desoldering operations.

3. Set the Temperature

CAUTION: Always set the temperature to as low as possible for the work being done.

The unit have two kinds of temperature setup: Normal temperature setup and instant one.

The temperature can be set between 200°C and 480°C with temperature control knob. Please refer to the chart below, and set the temperature.

Temperature	P.W.B.
280–350 °C	Single-sided P.W.B.
320–400 °C	Through-hole P.W.B.
350–450 °C	Multi-layer P.W.B.

Set temperature normally

CAUTION: Make sure the temperature of the unit can be adjusted (password is OK or the password is initial). While setting the temperature normally, the heating element is off. If the “*” button is pressed for less than one second, the present temperature setting will be shown for two seconds and then the display will return to showing the nozzle temperature.

“▲” , “▼” : Choose the value. “*”: Choose the digit.

Example: 400°C to 350°C

1.

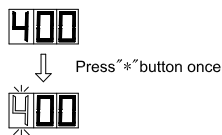

2.

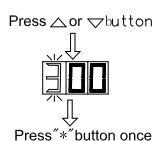

1. Push the “*” button and the hold it down for at least one second. The left-most digit (the 100’ s digit) in the display will flash. This indicates that the station is in temperature setting mode and that the 100’ s digit can be adjusted.

2. Select the desired value for 100’ s digit. Using the “▲” or “▼” button will change displayed value as follows.

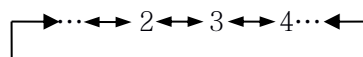

Press the “*” button when the desired value is displayed.

This will cause the middle digit (the 10’ s digit) in the display to begin flashing.

3.

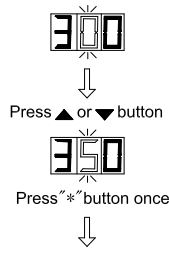

4.

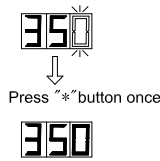

3. Select the desired value for the 10' s digit. Using the “▲” or “▼” button will change displayed value as shown below.

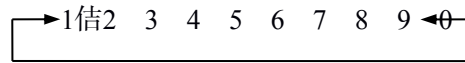

Press the “*” button.

The right (the 1' s digit) will then begin flashing to indicate that the 1' s digit can be set.

4. Select the desired value for the 1' s digit. Using the “▲” or “▼” button will change displayed value as shown above for the 10' s place selection.

Press the “*” button.

Here, pressing the “*” button...

- a) enters the temperature setting into the internal memory.
- b) displays the temperature setting, and
- c) starts heater control.

Note: If you turn off the power switch during the temperature setting, setting value will not be stored in the memory.

If the temperature value outside of this range is selected, the display will return to flashing the 100' s place. If this happens, reenter a correct temperature value.

Set temperature on-line

In the work, if it is necessary to set temperature quickly and the heat elements can not be cut off, the way may be selected.

Temperature rising:

Don' t press “*” knob, and press“▲” knob directly. If so, the setting temperature will raise 1°C and the display window will display the set temperature. When loosen the “▲” knob, the display window will display the set temperature about 2 seconds. If within 2 seconds of time, press the “▲” knob again, the setting temperature will raise 1°C again. If press the “▲” knob and not loose at least 1 second, the setting temperature will rise rapidly. Till the needed temperature reaches, then loose the “▲” knob.

Temperature dropping:

Don' t press “*” knob, and press “▼” knob directly. If so, the setting temperature will drop 1°C and the display window will display the set temperature. When loose the “▼” knob, the display window will

relay the set temperature about 2 seconds. If within 2 seconds, press the “▼” knob again, the setting temperature will drop 1°C again. If press the “▼” knob and not loose at least 1 second, the setting temperature will drop rapidly. Till the needed temperature reaches, then loose the “▼” knob.



4. Set Parameters

The station has the following parameters. Parameters setting can be adjusted.

password

The initial password in station’s memory is “000”. The setting temperature is admitted in this state. If need to restrict the setting temperature, the password must be changed.

Enter into setting the password

1. Turn off the power switch. Press and hold the “▲” and “▼” buttons simultaneously, then turn on the power switch.
2. Continue holding down the “▲” and “▼” button until the display shows  .
3. When the display shows  ,the station is in parameter-input mode.

Input Previously Password

4. Press the “*” button, the display shows  , and the left-most digit (the 100’s digit) in the display will flash. This indicates the station is in password setting mode and the 100’s digit can be adjusted. Using the “▲” or “▼” button will change displayed value. Set the password value in the same way described in “set temperature normally”. After selecting the password of three digit, press”*” button.

The input password is error





5. If the display window shows the present setting temperature, two seconds later, the station is in normal work state. This indicates the password of input is error, and the temperature setting can’t be done.

The password of input is correct

6. If the display window shows  , this indicates the password of input is correct. After displaying about 4 seconds, the station comes into normal work state, and the setting temperature will be admitted

Input New Password



Repeat the new password

7. When display window is showing  , press "*" button, and shows  , It indicates the unit comes into inputting new password state. Pressing "▲" or "▼" button will change displayed value. See "set temperature normally"
8. When three digits are selected, press "*" button, the display window shows  again. Now must input the new password. Repeat the same steps.
9. If the password is the same as last time, the changed password is OK. The new password is stored into the internal memory.
10. If the password is not the same as last time, and the display window shows  , the station will need to rewrite new password. (see the last 8-9 step). The changing of password is finished until the lately two passwords are identical.

*Note: The word of password is 0 to 9, ten words. If not , the changed password is unsuccessful.

Working Mode

Working Mode Setting

If the display window shows  , press and hold the "▲" and "▼" buttons simultaneously, then the display shows  . This indicates the unit comes into working mode setting state, and pressing "▲" or "▼" button will change displayed valve as shown below:



After selecting the working mode, press "*" down. The working mode is stored into the internal memory.

Please refer to the “Working Mode Table” for the meaning of the digit displayed.

Note: “X” represents the original working mode digit.



Warning: The heater and soldering tips will be seriously oxidized or damaged when working with a high temperature. So please choose the working mode carefully and try to operate with a lower temperature if possible.

Working mode table

Working mode	Temperature range	Handle type	Remark
0	200°C~450°C	Desoldering gun and Soldering iron	Auto sleeping
1	200°C~480°C	Desoldering gun and Soldering iron	Auto sleeping
0.	200°C~450°C	Desoldering gun and Soldering iron	No sleeping
1.	200°C~480°C	Desoldering gun and Soldering iron	No sleeping

5. Sleeping

If sleeping and working mode are selected, and the desoldering gun is not used for 20 minutes, the power to the heating element will be decreased, and the display shows . This state is sleeping mode. When the unit is in sleeping mode, the nozzle temperature will decrease to 200 °C (if the set temperature is more than or equal to 200 °C) or 50 °C (if the set temperature is less than 200 °C) and remain the temperature until resuming the unit.

To resume soldering, there are several ways as follows:

1. Cycle the power switch OFF, then ON.
2. Hit any button.
3. Press the trigger of gun.

If the unit is not resumed more than 40 minutes after it comes to sleep, the power supply will be shut off automatically, and the display window will not show anything.

6. Calibrate Temperature

The desoldering gun’s temperature should be recalibrated after replacing the iron or heating element or nozzle every time. The unit adopts digital calibration mode and input the revision value is input by pressing button, make the adjustment simply and quickly.

Method of recalibrating temperature: Use the thermometer to calibrate , and it is precise comparatively.

Calibrate by using thermometer

1. Set the unit's temperature to a certain value.
 2. When the temperature stabilizes, measure the nozzle's temperature with thermometer and write down the reading.
 3. Press “*” button not loose and press the “▲” and “▼” button simultaneously, the soldering station enters into calibrating temperature mode.
 4. At the moment, the 100's digit of LED display temperature is flashing. Press the “▲” and “▼” button to select the value and press “*” button to select the digit. Input the reading of thermometer, and inputting method is the same as **Set temperature normally**. Press “*” button after inputting. Here, the whole calibration operation has been finished.
 5. If the temperature still has deflection, you can repeat calibration in accordance with above steps.
- * We recommend to use the 191/192 thermometer for measuring the tip temperature.
 - * If the unit is locked by password, it will not be able to calibrate the nozzle temperature and you must input the right password.

7. Operate

Melt the solder

Apply the nozzle to melt the solder after the temperature stabilizing.



CAUTION

1. Never allow the nozzle to touch the board itself.
2. To confirm that all the solder is melted, observe the inside of the hole and the back-side of the P.W.B. If this is difficult to do, try slowly moving the lead with the nozzle-if the lead moves, the solder is melted.
3. Never move the lead by force, If it doesn't move easily, the solder isn't yet fully melted.

Absorb the solder

After confirming that the solder is completely melted, absorb the solder by squeezing the trigger on the gun.

After fully absorbing all the solder, cool the soldering junction in order to prevent it from becoming resoldered

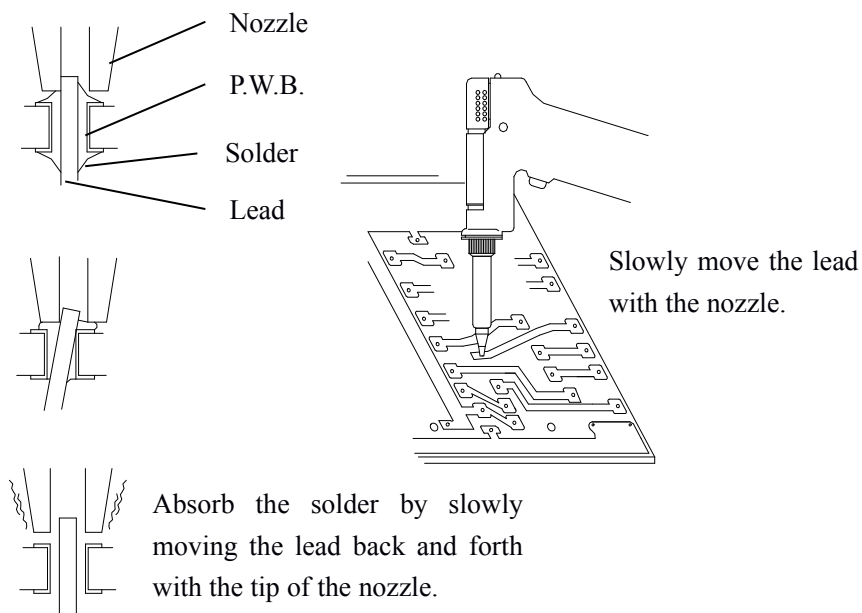

CAUTION: Never leave any solder remaining inside the hole in the P.W.B.

Problems during desoldering

If solder remains, resolder the component and repeat the desoldering process.

Clean the tip of the nozzle

Keep the solder-plated section of the nozzle a shiny white by coating it with a small amount of solder.

If the tip of the nozzle is coated with oxide, the nozzle's heat conductivity will be lowered. Coating the tip with a small amount of fresh solder ensures maximum heat conductivity.

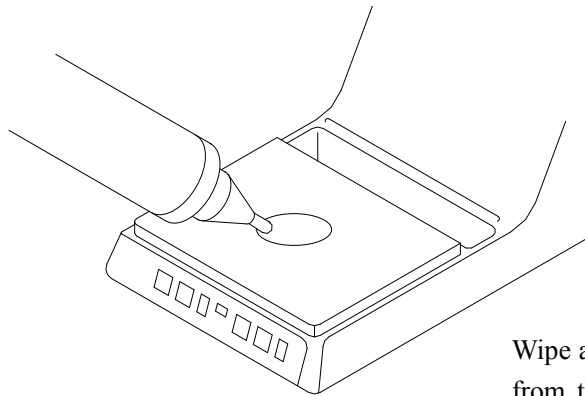

Wipe away any oxide or old solder from the nozzle using the hole in the center of the sponge.

IV 、 Cleaning During the Process of Operation

The solder absorbed by nozzle must be cleaned in time to insure the unit work normally.

1. Observing the Indicator

While looking at the indicator and with the hole of the nozzle open, pull the trigger and look at the indicator .If it is red, clean the nozzle and heating element, empty the filter pipe, and replace the filters. If the indicator is blue, cleaning is not necessary and operations can be resumed.

CAUTION: The indicator will not operate accurately if the hole of the nozzle is closed or if the solder in the hole of the P.W.B. is not melted.

If there is a noticeable drop in suction efficiency, clean the nozzle and heating element with the cleaning pin.

Normal	Abnormal	Solution
Blue or slight amount of red can be seen.	More than half of the indicator is red.	If the indicator is more than half red, replace the filter and clean the nozzle and the inside of the heating element..

2. Replacing the Filter Pipe

Replace the filter pipe as shown step ①~③. During operation, the filter pipe is very hot. Wait until the filter pipe is cool before replacing the filter. We recommend keeping a second filter pipe containing new filters handy, and replacing the installed filter pipe with this backup filter pipe.

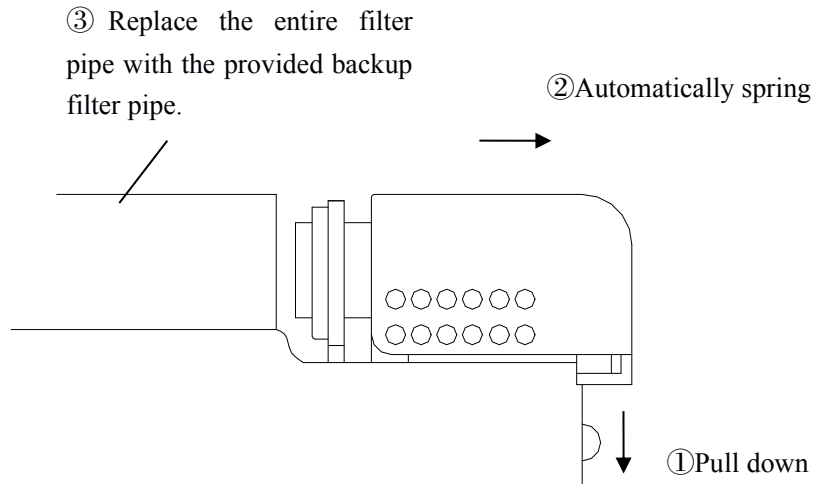

V、 Error Messages

Various error messages will be displayed when there is a problem with the unit. If the following message is displayed, see the trouble shooting guide.

S - E Sensor Error

If there is a possibility of a failure in the sensor or anywhere in the sensor circuit, **S - E** will be displayed and power to the soldering iron will be cut off.

Flash the Temperature Display

If power is being sent to soldering iron and the tip temperature goes below the setting temperature about 80 °C , the temperature display will flash. Draw your attention to this.

Note

H - E Heater Error

If power can't be sent to soldering iron, the display window will show **S - E** . This indicates the possibility of a heater malfunction.

VI、 Trouble Shooting Guide

Warning:

- * Disconnect the power plug before servicing. Failure to do so may result in electric shock.
- * If the power cord is damaged, it must be replaced by the manufacturer, its service agent or similarity

qualified person in order to avoid personal injury or damage to the unit.

1. The solder in the junction is not sufficiently melted

- **Temperature is not high enough.**

The following parts require a greater heat capacity to desolder.

Use a preheating oven or heating gun to heat the P.W.B. to a temperature that won't damage the board or its components then desolder. Do not only increase the temperature of the gun, otherwise too high temperature may damage the P.W.B. and its components.

- **Nozzle is worn out.**

When the nozzle begins to wear out, the heating efficiency begins to decline. Check the nozzle. If the solder plating is damaged, or the nozzle is eroded, replace the nozzle.

2. Suction power is dropping

- **Replace the filters, and clean the nozzle and the inside of the heating element.**
- **Air is leaking from the vacuum system.**

Air leakage cannot be determined from the indicator. Check the air-tightness of the following parts and replace that are worn.

- | | |
|--|-----------------------------|
| a. Contact point of the nozzle and heating | d. Hose |
| b. Front holder and nearby parts | e. The tie-in |
| c. O-ring in the back holder | f. Packing and nearby parts |

3.LED display does not light up.

- **Is the power cord plugged in correctly?**
Securely insert the power cord into the power supply.
- **Is the fuse blown?**
Determine why the fuse blew and eliminate the cause, then replace the fuse.
 - A Is the inside of the unit short-circuited?
 - B Is the grounding wire touching the heating element?
 - C Is the heating element lead twisted and short-circuited?

4.Pump does not operate.

- **Is the cord assembly properly connected?**
Reconnect the cord assembly.

5.Solder is not being absorbed.

- **Is the spring filter full of solder?**

Replace it with a new one.

- **Is the ceramic filter hardened?**

Replace it with a new one.

- **Is there a vacuum leak?**

Check the connections and replace any worn parts.

- **Is the nozzle or hole in the heating element clogged?**

Clean it.

6. The nozzle does not heat up.

- **Is the desoldering gun cord assembly properly connected?**

Reconnect it .

- **Is the heating element damaged?** (Is the heating element broken as follow)

Replace it .

A	Between pins 4&5 (Heating element)	Under 1 Ω (Normal)
B	Between pins 1&2 (Sensor)	Under 10 Ω (Normal)
C	Between pins 3&Nozzle	Under 2 Ω

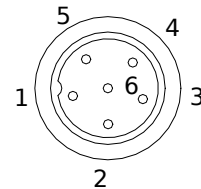

7. Heater error **H—E** is displayed.

- **Is the desoldering gun cord broken?**

Replace it

- **Is the heating element broken?**

Replace the heating element.

- **Is there a nozzle on the gun?**

Assemble a nozzle on the gun.

8. Can't set the temperature.

- **Is the button on the panel locked by password?**

Enter into the setting password.

Note: When repairs are needed please send both the desoldering gun and the station to your sales agent .

VII、 Maintenance and servicing

Properly maintained, the desoldering gun should provide years of good service .

Efficient desoldering depends upon the temperature, and the quality and quantity of the solder and flux.

Perform the following service procedures as indicated by the conditions of the gun's usage.

Warning: Since the desoldering gun can reach a very high temperature, please work carefully .

Except when cleaning the nozzle and heating element, always turn the power switch off and disconnect the power plug before performing any maintenance procedure.

1. Post-operation Maintenance :

TO ensure a long service life, always perform the following maintenance procedures immediately after using the unit.

⚠ Remove all solder from the inside of the nozzle and heating element.

⚠ Clean the tip of the nozzle with the cleaning sponge, then coat the tip with a fresh layer of solder to protect the solder plating.

2. Servicing the Desoldering Gun

⚠ CAUTION The desoldering gun will be extremely hot. During maintenance, Please wear gloves and work carefully.

① Inspect and clean the nozzle.

- Plug in the power cord, turn the power switch On and let the nozzle heat up.
- Clean out the hole of the nozzle heat up.

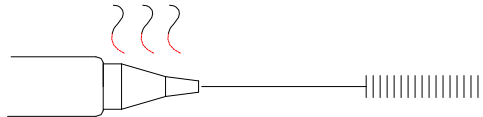

The cleaning pin passes completely through the hole.

⚠ CAUTION: The cleaning pin will not pass through the nozzle until the solder inside the nozzle is completely melted. Please use the proper sized cleaning pin for the nozzle diameter.

- Check the condition of the solder plating on the tip of the nozzle.

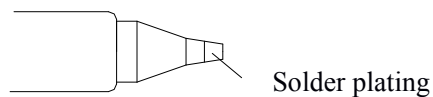

Solder plating

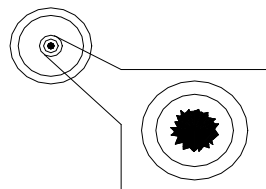

Diameter of hole is widened through erosion.

- If it is slightly worn, recoat the tip with fresh solder to prevent oxidation.
- Check the condition of the surface and inside hole of the nozzle.
- If either is worn or eroded, or the inside diameter seems unusually wide, replace the nozzle.

⚠ CAUTION:

1. Unfortunately, it is often difficult to observe this condition. Therefore, if desoldering efficiency goes down and all other parts appear to be OK, the nozzle is probably eroded and should be replaced.
2. The inside hole and the surface of the nozzle is plated with a special alloy. Should this alloy become eroded by high-temperature solder, the nozzle will not be able to maintain the proper temperature.

② Disassemble the heating element

Remove the nut with the heat resistant pad.

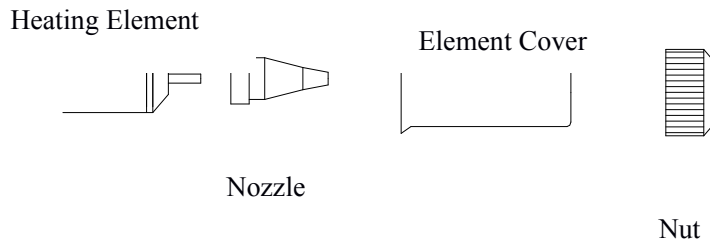

③ Clean out the hole in the heating element with the provided cleaning pin.

CAUTION: Be sure the solder in the hole in the heating element is completely heated. Before cleaning the hole.

⚠ If the cleaning pin cannot pass through the hole, replace the heating element.

⚠ Turn the power off after cleaning.

④ Replace the filters.

⚠ Turn the power switch OFF.

⚠ When the filter pipe is cool to the touch, push down the release knob at the back of the gun and remove the filter pipe.

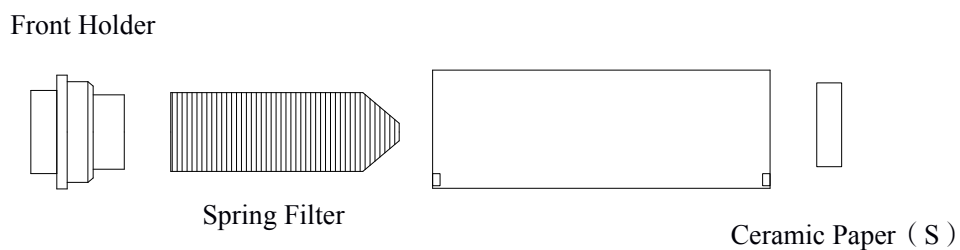

CAUTION: The filter pipe is very hot.

⚠ Inspect the front holder.

Replace: Stiff and cracked.

⚠ Inspect the spring filter.

Replace: Solder is collected in two-thirds of the spring filter.

⚠ Inspect the ceramic paper filter (S)

Replace: Ceramic paper filter is stiff with flux and solder.

⑤ **Secure the filters.**

⚠ Attach the spring filter to the front holder.

⚠ Attach the front holder to the filter pipe.

 **CAUTION:**

1. Be sure the front holder is correctly aligned.
2. Use the ceramic paper filter(S) for the filter pipe (gun). Using of the ceramic paper filter (L) in the filter pipe may cause to break or the power to drop.

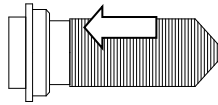

Ceramic Paper Filter(S)

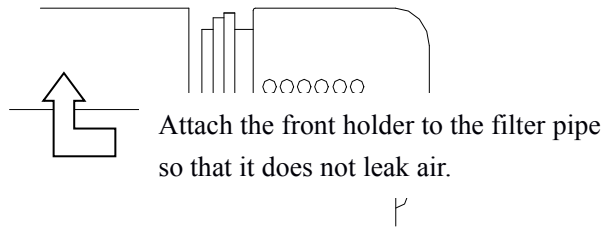

Firmly press the back holder assembly into the filter pipe
in order to properly seat the O-ring against the pipe.

⑥ Assemble the heating element

⚠ Attach the nozzle and securely tighten the nut with the attached heat resistant pad.

⚠ CAUTION: If the nut is loose, air will leak and the temperature will drop.

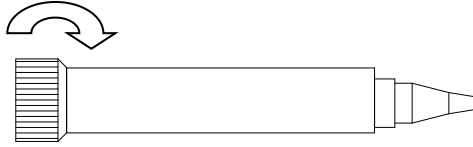

3. Maintenance (Station)

① Replace the outside filter

The filter is expendable, it often should be replaced to ensure the suction is normal.

Pull out the hose each side filter take out it, replace the new one. (See the connection part)

② Cleaning the Pump

⚠ CAUTION: Unplug the power cord before starting this procedure.

⚠ Disassemble the pump heads

Disassemble the rear panel and remove the cover, take out the pump head from each side of the pump.

⚠ Clean the pump head

Remove the valve plate and fixing plate and clear any flux adhering to the plates.

⚠ CAUTION:

1. If the fixing plate is difficult to remove, apply hot air to it to warm it up. Never use excessive force to remove the plate as it is easy to bend, and a bent plate will allow air to leak out and reduce solder vacuuming efficiency.
2. Clean the plates only with alcohol or thinner.

⚠ Replace

If the valve plate is bent or stiff, replace it. If the exhaust filter is dirty, replace it.

⚠ Assemble the pump heads

Reassemble the valve plate and fixing plate.

⚠ CAUTION: When assembling the pump, be sure to check for air leaks.

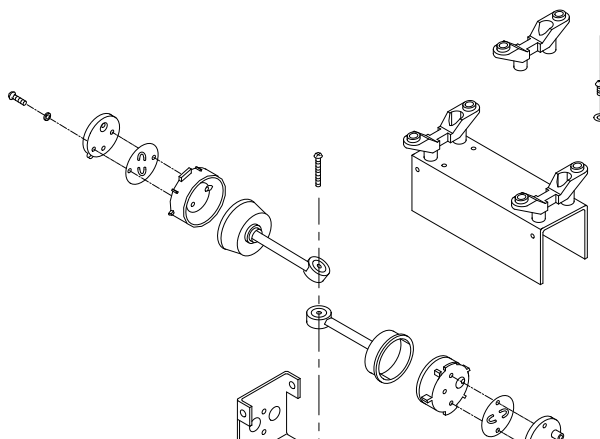

Be sure the parts are aligned correctly.

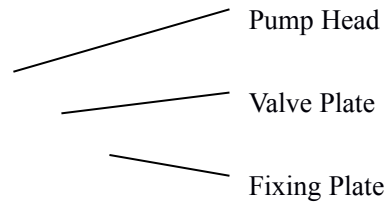

VIII、 Replace Parts

Replacing the Heating Element

⚠ CAUTION: Unplug the power cord before starting this procedure.

The resistance value of a working heating element is below $1\ \Omega$ at $23\ ^\circ\text{C}$. If the value you get is outside this range, replace the heating element.

- ① Disassemble the heating parts.
- ② Separate the housing.
- ③ Detach the terminal and remove the heating element.
- ④ Insert a new heating element and reassemble. (Heating element 36V-90W)
- ⑤ Recalibrate the temperature.

The resistance of new heating element varies, resulting in variations in operating temperatures. It is necessary to recalibrate the temperature every time the heating element is replaced. (**See the Calibrate temperature**)

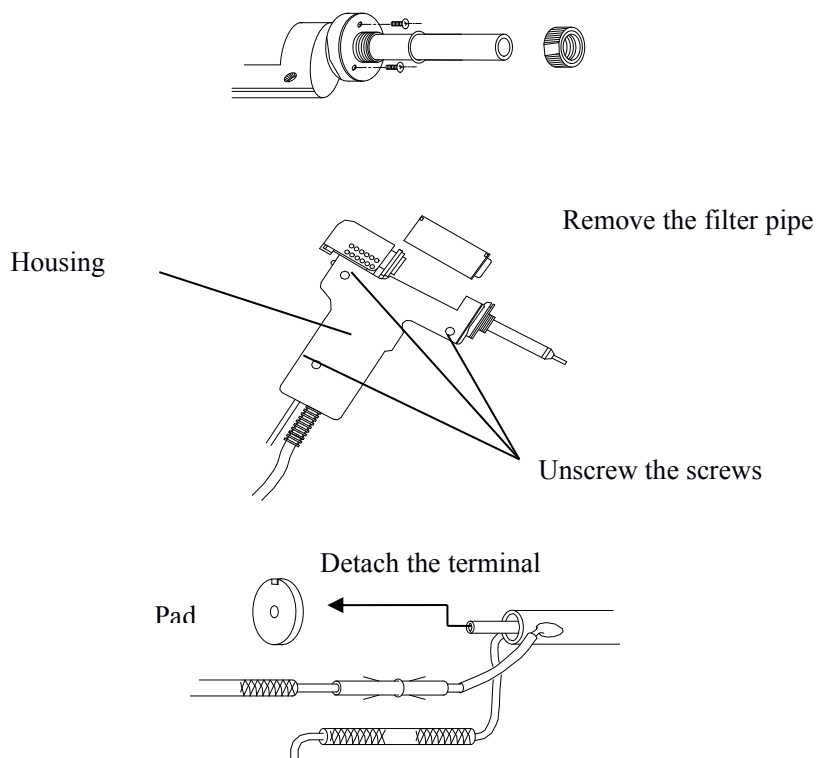

IX、 Replaceable Parts

Parts List (Desoldering Gun)

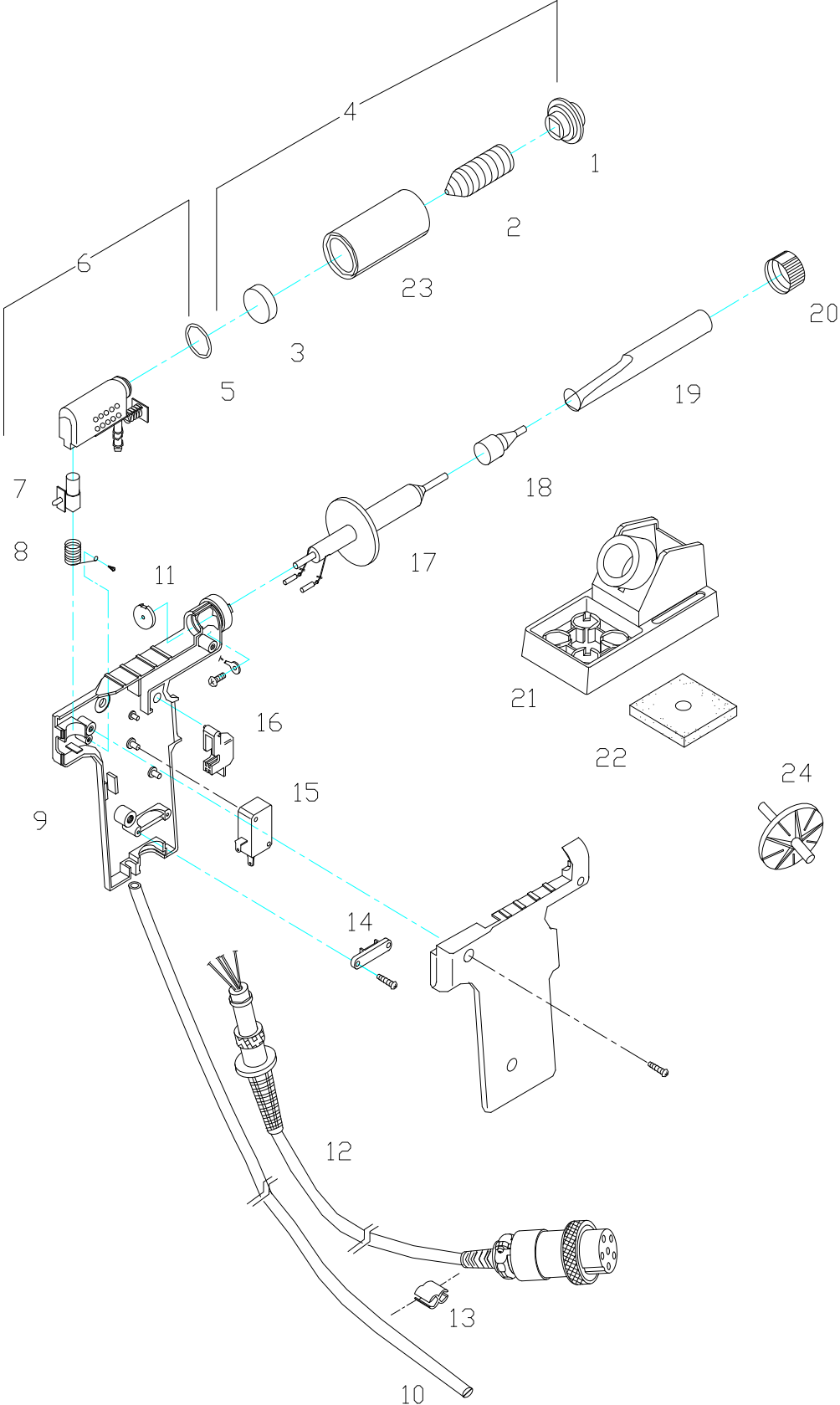

Item No.	Part No.	Part Name	Description
1	45001	Front Holder	
2	14001	Spring Filter	Without Front Holder & Spring Filter
3	47044	Ceramic Paper Filter(S)	
4	47001	Filter Pipe	(Assembly) With Front Holder & Spring Filter
5	26099	O-ring	
6	47002	Back Holder Assembly	
7	42001	Release Knob	
8	14002	Spring For Release Knob	
9	41001	Housing	
10	55049	Hose	
11	45002	Packing	
12	47003	Cord Assembly	w/Micro Switch & Plug
13	42148	Cord Holder	
14	44043	Cord Stopper	
15	12128	Micro Switch	
16	42005	Trigger	
17	47011	Heating Element	
18	24285	Φ0.8mm Nozzle (A1004)	(0.03in) Expendable
	24284	Φ 1.0mm Nozzle (A1005)	(0.04in) Expendable
	24283	Φ 1.3mm Nozzle (A1006)	(0.05in) Expendable
19	44235	Element Cover	
20	44006	Nut	
21	43001	Iron Holder	
22	20011	Cleaning Sponge	
23	41001.4	Filter Pipe	Without Front Holder & Spring Filter
24	42326	External Filter	Connect to the hose of gun (Expendable)