

Exclusively Distributed, Serviced in India by Inde Enterprises



Reel Estimator
SpotCheckTM

Exclusive Indian Distributor



The **SpotCheckTM Reel Estimator** quickly determines counts to within 5%. This is an affordable handheld meter designed for inventory management and job setup to determine tape and reel part counts. This meter provides accurate estimates without the cost or complexity of a bench top counter.

Features

- Suits for all tape widths/thicknesses/component types
- Works with both 7" (18cm) & 13" (33cm) reels
- Estimates component counts to within 5%
- Self-contained, handheld, battery powered
- Patented Design (US Patent #8,245,412)
- CE and RoHS Compliant
- Made in USA

Specifications

- Tape & Reel Requirements** : Requires standard 4mm pitch feed holes on tape and 13mm center hole in reel.
- Fits Reel Sizes** : 7 inch(18cm) and 13 inch(33cm) reels
Note: 15 inch(38cm) reels possible with user supplied ruler
- Fits Part Spacing** : 2mm to 40mm part spacing on tape (Pitch)
- Accuracy** : +/- 5% on part count
- Battery** : One (1) 9 volt size alkaline battery 1 Year Battery Life or Approx 1000 readings
- Meter Size** : 7.5in(19cm) x 4in(10cm) x 1in(2.5cm)
- Meter Weight** : 0.4lbs(180 g)
- Environmental** : at 32-104°F(0-40°C) with 0-90% RH

How it works:

- 1) Place gauge plate into center hole of reel. Read the outer diameter of the tape wrapped on the reel. Enter this number as the OD value.
- 2) Read the inner diameter of the first wrap of tape. This is also the diameter of the hub of the reel. Enter this number as the ID value.
- 3) Count the number of feed holes between the centers of two consecutive parts & enter this as the holes value. Very small parts will only have one hole per two parts so this would be entered as 0.5 on the LCD.
- 4) Use the gauge plate to measure the thickness of the tape. Be sure to be very accurate with this measurement and don't forget to measure the full thickness of the tape including the thickness of removable cover film. For thin tape use the slots of the gauge plate. For thicker tape use the ruler along the back edge of the gauge plate. Best results are achieved by unwinding a short leader of tape to accurately determine which slot is the best fit on the gauge plate.
(NOTE: while estimates of thin tape are possible by visual comparison to slot widths without unwinding any tape, this method often leads to greater error in the count)
- 5) Once all measurements have been accurately set the PART COUNT will be correctly displayed on the LCD. To count another reel simply change only the values that differ on the LCD. (For similar parts it may only be necessary to change the OD value for each reel being counted.)

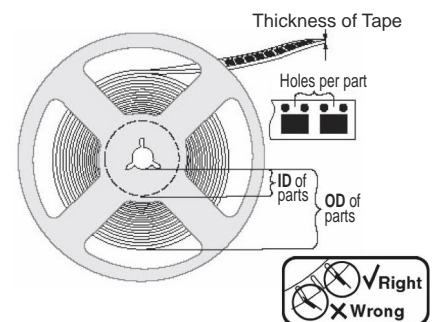

Video available at www.indeonline.in, Call us for demo

shown trademarks are property of their respective owners.
While the information contained herein in, has been carefully compiled to the best of our knowledge, nothing is intended as representation and warranty on our part; and no statement shall be construed as recommendation to infringe any of existing patents. We accept no liability of whatsoever for any faults and errors in the information contained herein. Contents of this catalogue and specifications of the products, are subject to change without notice due to continuous improvements.